

The Paleolithic of Crimea, III

The Middle Paleolithic and
Early Upper Paleolithic of
Eastern Crimea

Edited by

Victor P. Chabai, Katherine Monigal & Anthony E. Marks

Offprint

Etudes et Recherches Archéologiques de l'Université de Liège

ERAUL 104

2004

Planning Depth and Saiga Hunting: On-Site and Off-Site Activities of Late Neandertals in Level B1 of Buran-Kaya III

Thorsten Uthmeier

Buran-Kaya III, situated near the eastern bank of the Burulcha River and approximately 20 km southwest of Belogorsk, belongs to the eastern group of Paleolithic sites on the Crimean Peninsula. Buran-Kaya III itself is a partly collapsed rockshelter (Marks and Monigal 2000a:213) with an entrance exposed to the south. Today, the space under the roof is 3 m to 5 m wide and up to 6 m deep (Yanevich 1998:133). In the direction of the river, a steep cliff drops about 10 m down to the river terrace (Figure 12-1). The Burulcha River has a differential flow depending on the season from higher elevations to the northern steppe zone and, in doing so, has cut its bed deeply into the second ridge of the Crimean Mountains. Although a part of this second ridge is characterized by small valleys or even canyons and elevated questas in western Crimea, the landscape around Buran-Kaya III (Figure 12-1) consists of gentle hills and wide valleys that connect the northern steppe plain with higher regions of the first ridge of the Crimean Mountains. There are, however, also more elevated limestone massifs, as at the Zaskalnaya sites, steep cliffs near Sary Kaya, and deeply incised rivers like the Burulcha at Buran-Kaya III.

The topographic setting must be considered as attractive to Pleistocene hunters. The combination of a wide valley suitable for the seasonal migrations of big herds of ungulates, a small river with aquatic resources, the possibility of hunting parts of herds or individuals, and the excellent overview from elevated areas

must have seemed advantageous to those looking for a promising logistical territory. The assumption that hunting, especially of *Saiga tatarica* (Patou-Mathis, Chapter 8), and, perhaps, gathering for other food resources were the main reasons to come to this area is underlined by the fact that there was no easy access to raw material in the vicinity of Buran-Kaya III. The nearest known outcrops are close to Tsvetochnoye and Russakovka, some 10 km to 15 km downstream along the Burulcha River, as well as in the vicinity of Zaskalnaya in the Biyuk-Karasu Valley, more than 20 km to the east (Demidenko, Chapter 9). According to our own preliminary surveys, the riverbed of the Burulcha River lacks suitable raw materials (pebbles larger than 3 cm) for a distance of 5 km from the site. The fact that not only rockshelters, but also Middle Paleolithic open-air sites like Krasnaya Balka and Sary-Kaya are known from eastern Crimea again reinforces the assumption that, in some cases, Neandertals made their decisions to stay in a region mainly based upon the availability of food sources. Apart from access to water, other simple criteria that are often supposed to be relevant for the placement of Paleolithic camp sites, such as short distances to raw material sources and/or any given topographical structure, such as caves or rockshelters, seem to have been less important.

Because the history of the excavations and the stratigraphic sequence have already been described in detail (Yanevich et al. 1996; Yanevich 1998; Marks and Monigal 2000a; Chapter 1), I only want to repeat

some important aspects regarding Level B. The excavations, including sondages made before 1996, are supposed to have uncovered the entire extension of preserved in situ archeological layers, since tests to the west, east, and south all exposed sharp erosional contact between the in situ layers and steeply bedded slopewash (Demidenko, Chapter 9).

In general, the stratigraphy of Buran-Kaya III is characterized by a low rate of sedimentation. Although the archeological layers span, with several hiatuses, a time range of more than 38,000 years (Pettitt 1998a; Marks and Monigal 2000a), the thickness of the cave filling measures only 3 m at the entrance and 1 m at the back wall. As a consequence, only minimal or no sterile

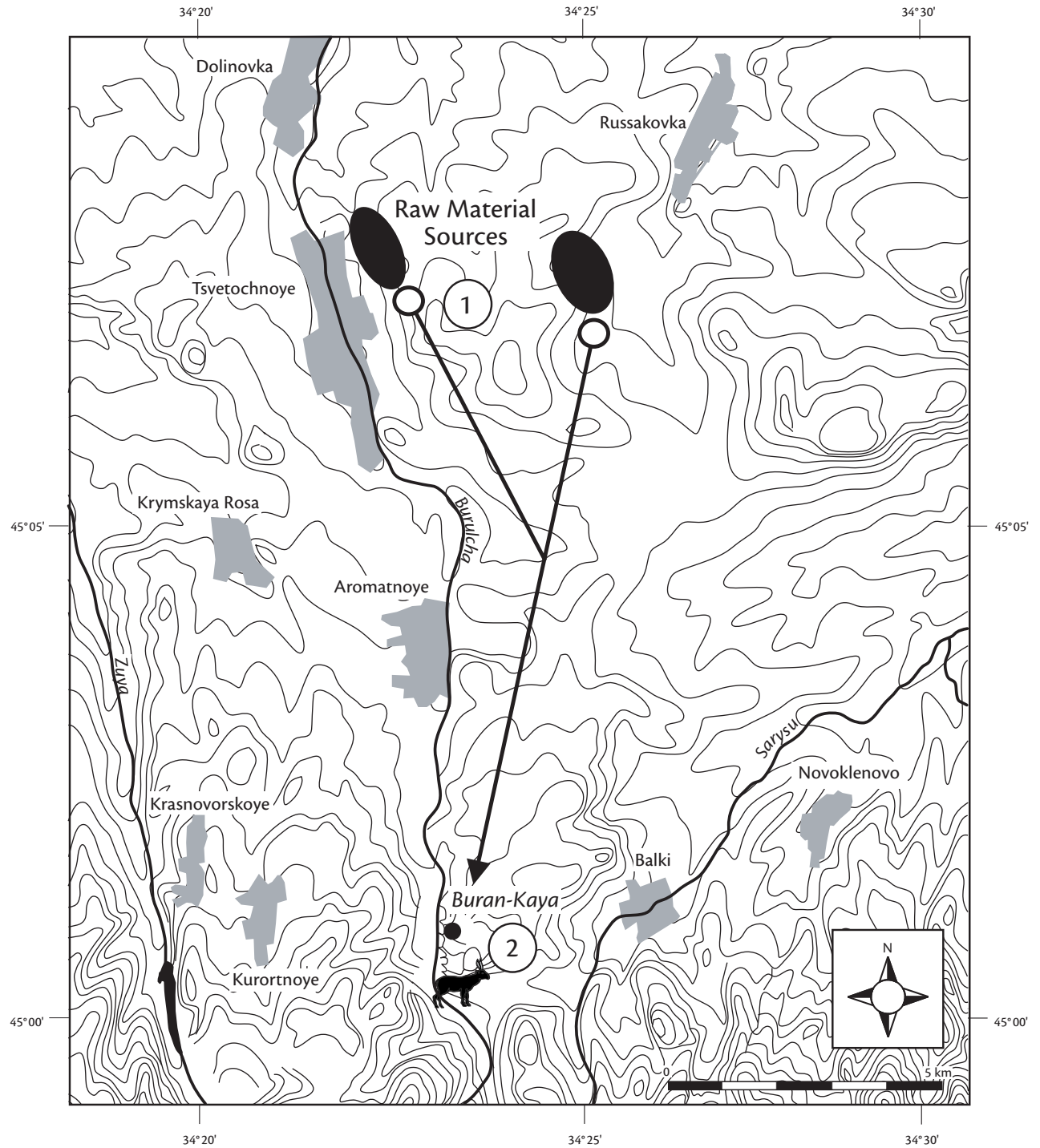

Figure 12-1—Map of the vicinity of Buran-Kaya III (2) and major outcrops of Cretaceous flint (1).

1
2
3
4
5
6
7
8
9
10
11
12
13
14
15
16
17
18
19
20
21
22
23
24
25
26
27
28
29
30
31
32
33
34
35
36
37
38
39
40
41
42
43
44
45
46
47
48
49
50
51
52
53
54
55
56
57

sediments were observed between most archeological horizons during the 1996, 1997, and 2001 excavations. While Layer B is separated by thin archeologically sterile sediments from the underlying Eastern Szeletian horizon C (Marks and Monigal 2000a, Chapter 1) and from the overlaying Upper Paleolithic Layers 6-5, 6-4, and 6-3 (Yanevich 1998; Marks and Monigal, Chapter 1), no sterile sediments except for some local lenses of debris were found within Layer B itself. Layer B, with a thickness of 30 cm to 35 cm, is described as fresh limestone debris, perhaps pointing to a cold (stadial) environment, within a sandy silt matrix. Despite marked lithological similarities, however, two separate levels were recognized, based on differential sediment coloration. Whereas Level B, with a thickness of 0 cm to 15 cm, is yellow-brown, the underlying Level B_I is dark-brown to black and 20 cm thick. The dark color of Level B_I is supposed to have resulted, at least in part, from a number of fireplaces that were destroyed by weathering and/or intensive human activities. No intact fireplace and no clearly limited zones of activity were observed, however, during the excavations.

The numerous stone artifacts from Buran-Kaya III Levels B and B_I are classified as Middle Paleolithic Kiik Koba facies type, characterized by high numbers of simple convergent tools (convergent scrapers and points), and plano-convex surface-shaped points and scrapers of comparably small size. Today, the marked typological differences between assemblages of Kiik Koba type and other industries of the Crimean Micoquian are considered to result from intensive and repeated, but short-term, camps far away from raw material outcrops (Demidenko, Chapter 9). Absolute AMS dates (Marks and Monigal 2000a:table 1) place

Levels B and B_I of Buran-Kaya III not only at the end of the development of the Crimean Micoquian, but also at the very end of European Middle Paleolithic, in general. If the dates are correct, then the finds from Levels B and B_I of Buran-Kaya III also represent some of the youngest-known traces of Neandertals, because in the upper layer of the eponymous site, the Kiik Koba facies was associated with the remains of *Homo sapiens neandertalensis* (Bonch-Osmolowski 1941, 1954).

Given the stratigraphic position of Levels B and B_I between the Streletskayan-related Level C, and the clearly Upper Paleolithic of Level 6-5 (Marks and Monigal, Chapter 1), this Middle Paleolithic of Kiik Koba facies is interstratified between two Upper Paleolithic occupations.

The typo-technological analysis by Demidenko (Chapter 9) showed long reduction sequences of scrapers, an intensive resharpening of simple and surface-shaped tools, as well as an intensive use of cores and preforms for blank production. The present article focuses on the settlement pattern that might explain these observations. The data used here are derived from a sorting of artifacts from the 1996 excavation of Level B_I into raw material units and they are interpreted as resulting from different on-site and off-site activities. The method used is a transformation analysis based on raw material units as equivalents of single pieces or workpieces (Weissmüller 1995; Uthmeier, Chapter 11). Additional information comes from the analysis of operational steps in the production of surface-shaped tools (Richter 1997; Richter, Chapter 13) and the analysis of the numerous faunal remains (Patou-Mathis, Chapter 8).

The Sample: Artifacts from the 1996 Excavation of Buran-Kaya III Level B_I

Despite the fact that the typo-technological analysis (Demidenko, Chapter 9) and the transformation analysis presented here are based on the same artifact sample from the 1996 excavation of Level B_I at Buran-Kaya III, there are some differences between the data sets (Table 12-1). Most of these differences, however, result from the exclusion in this study of unretouched pieces under 3 cm in maximum dimension, as well as patinated or burned artifacts. Neither group of artifacts can be used because: (a) the sorting of raw materials into separate, distinct nodules (workpieces) by macroscopic attributes cannot be done on such material and (b) transformation analysis looks for the presence or absence of phases of the *chaîne opératoire* within these small raw material units by classifying artifacts, in part, by their dorsal scar pattern, which is difficult with very small pieces. Thanks to modern excavation methods, including sieving, the sample

includes 13,690 items, of which 90% is unretouched chips under 3 cm (Figure 12-2) and these do not appear in our data. Retouched pieces under 3 cm, including chips from the resharpening of tools, broken tool tips, and others, account here only for 126 pieces or 16.8%. In addition, 610 heavily burned pieces recognized by Demidenko and 49 patinated artifacts were excluded from the sample for the transformation analysis. Altogether, that part of the assemblage used for transformation analysis comprises 866 artifacts.

Other differences between our and Demidenko's samples, however, relate to different classifications. Unaware that a good part of the tools counted by Demidenko might be patinated artifacts excluded from our sample, we were obviously much stricter in the classification of formal tools and pieces with irregular retouch. Compared with Demidenko's data then, the number of tools in the data used for the trans-

TABLE 12-1

Comparison between the complete list for blank categories given by Demidenko (Chapter 9) and the sample used in the transformation analysis (this chapter). For categories that were used for the transformation analysis (shaded), a correlation index (Pearson's r) was calculated that shows that both sets of data are nearly identical.

Category	Demidenko	This analysis
Simple chips	13,690	7
Burned pieces	610	15
Waste rejuvenation	110	119
Chunks		42
Flakes and blades	367	382
Cores, preforms, and nodules	15	18
Simple tools	269	170
Irregular or marginal retouch	88	68
Surface shaped tools	56	45
Total	15,215	866
Correlation r (Demidenko/this analysis) = 0.945		

Items not used in the sample for this analysis:

Due to uncertain classification of *chaîne opératoire* phase

Simple chips 13,690

Due to classification as "sorting rest"

Heavily burned pieces 610

Patinated pieces 49

Total 15,215

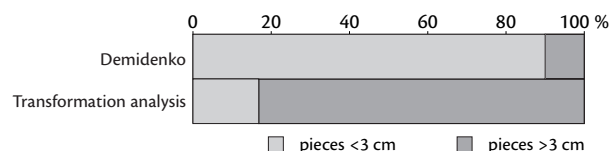

Figure 12-2—Pieces less than 3 cm in the original sample of Level B1 (Demidenko, Chapter 9) and in the sample used for the transformation analysis. Since the sorting of raw material was based on macroscopic attributes, simple chips < 3 cm were excluded from the transformation analysis.

formation analysis is much lower. Because flakes and blades are consequently more numerous, a number of simple tools he recognized were seemingly not classified by us as retouched at all, or, in some cases, were classified as waste from rejuvenation. Some preforms, nodules, or heavily fragmented bifacial tools, as well as some small tool fragments in Demidenko's type list were most likely classified by us as chunks. Although differences of this kind may be in accordance with our expectations, it is at the same time important that independent classifications of the same assemblage lead to similar, if not identical, results. Here, the correlation coefficient Pearson's r (which ranges from -1

TABLE 12-2

Comparison of the general structure of Levels B and B1 of Buran-Kaya III. According to the correlation index (Pearson's r) calculated for formal tools and blanks, the assemblages are nearly identical.

Tools (reduced list)	Level B1	Level B	Level B1	Level B
Bifacial points	21	7	5.1	5.3
Bifacial scrapers	5	4	1.2	3
Bifacial denticulates	2	—	0.5	—
Bifacial fragments	22	4	5.3	3
Bifacial preform	6	2	1.5	1.5
Retouched pieces	88	34	21.3	25.8
Simple scrapers	42	8	10.2	6.1
Transversal scrapers	19	14	4.6	10.6
Double scrapers	7	9	1.7	6.8
Convergent scrapers	48	17	11.6	12.9
Points	68	16	16.5	12.1
Denticulates	7	3	1.7	2.3
Notches	4	—	1	—
Perforators	2	1	0.5	0.8
Endscrapers	2	—	0.5	—
Burins	2	—	0.5	—
Unifacial fragments	68	13	16.5	9.8
Correlation r (tool classes B1/B) = 0.8816				
Total tool fragments	224	53	54.2	40.2
Total complete tools	189	79	45.8	59.8
Total bifacial tools	56	17	13.6	12.9
Total unifacial tools	357	115	86.4	87.1
Total tools	413	132	100.0	100.0
Blanks				
Obj. of primary flaking	25	12	0.2	0.6
Chips	13,690	1,776	92.5	89
Flakes	322	73	2.2	3.7
Blades	45	4	0.3	0.2
Cores	—	—	—	—
Burned pieces	610	106	4.1	5.3
Waste of rejuvenation	110	24	0.7	1.2
Correlation r (blank classes B1/B) = 0.9998				
Total blanks	14,802	1,995	100.0	100.0

for a perfect negative, 0 for no, and +1 for a perfect positive correlation) was used to examine the degree of similarity (Benninghaus 1982:214–229). If only the artifact categories suitable studied for transformation analysis are compared, the different classifications discussed here are nearly identical ($r = 0.945$).

The same correlation coefficient was used to investigate the degree of differences or similarities between Levels B and B1 (Table 12-2). The correlation coefficient, calculated separately for the reduced list of formal tool types and blank categories, shows striking degrees of similarity. The distribution of the frequencies of formal tools highly correlates, with r

= 0.882. The frequencies of blanks, with $r = 0.999$, indicate that the assemblages are statistically identical in this aspect. This has two implications for the overall interpretation: First, Level B1 may be taken as representative for both Kiik Koba levels, in terms of formal tool and blank frequencies. It is, therefore, reasonable to conclude that results obtained in the course of the analysis of Level B1 are also relevant for Level B. In both levels, nearly identical activities must have taken place. Second, there are good reasons to think that the same technological repertoire

was used to perform comparable *chaînes opératoires* in both levels. Because the same reduction and rejuvenation sequences occur, it is concluded that the same, or very similar, strategies of raw material procurement and similar movements in the landscape led to the striking similarities in the frequencies of formal tools and blanks. The fact that even the numbers of burned pieces are very similar can be seen as an indicator for a comparable intensity of the use of fireplaces and hearths during the stays of Neandertals in both levels.

Some General Observations Concerning On-Site and Off-Site Transformation of Stone Artifacts in Buran-Kaya III Level B1

The question as to what extent the transformation of raw material from nodules to blanks took place on-site, is often estimated by cortex frequencies. The interpretation of cortex frequencies is based on two theoretical assumptions. The first is that, because core reduction starts with the outer cortex and only after decortication and preparation reaches the inner part of the nodule, the presence of cortical flakes and high numbers of flakes covered partly with cortex is taken as an argument that the initial flaking of raw nodules took place on-site. If, at the same time, blanks without cortex appear in significant numbers, it is concluded that, in many cases, a great portion of the entire *chaîne opératoire* was conducted on-site. Second, because raw material acquisition is thought to be embedded in other activities of subsistence (Floss 1994:322–328), it is assumed that the frequency of cortex declines with an increasing distance to the raw material source: the more stops taken in between, the more often blanks were flaked from a nodule. Thus, if the provenance of the raw material is not known, a high percentage of cortical flakes and flakes with partial cortex is usually taken as an indicator for the procurement of mainly local raw material.

In the present data set, cortical blanks, blanks partially covered by cortex, and blanks without cortex on their dorsal surfaces have been counted; cores, however, were not studied for the condition of the cortex. In Level B1, 78 pieces (9%) are totally covered by dorsal cortex (Figure 12-3). Blanks that are partially cortex-covered account for 389 pieces (46%), and those without cortex make up 384 pieces (45%). The simple data structure, together with the above-mentioned theoretical implications, seems to reflect complete reduction on-site, with some initial cortical flakes and an equal proportion of flakes with some cortex derived from preparation, and flakes without cortex as products of a more evolved debitage. Without further controlling variables, one might conclude that many

local nodules went through decortication and interior flaking on-site.

Is it as simple as that, however? As an alternative, the following twofold treatment of raw material may also be postulated based on the data and theoretical implications presented above: Neandertals imported many blanks without cortex from more distant campsites, whereas some local nodules were decorticated and prepared, but these were taken to other sites without the flaking of their interiors (leaving cortical flakes and flakes with partial cortex at the site). It becomes clear that as soon as more complicated strategies of raw material procurement are considered, with different treatments of local and distant raw material sources, simple variables might lead to false interpretations. Because sophisticated strategies for raw material procurement (Chabai et al. 2000; Demidenko, Chapter 9), as well as for on-site and off-site tool production (Marks and Monigal 1998), are known for the Late Middle Paleolithic of Crimea, additional analysis is needed.

W. Weissmüller has suggested (1995:62) that the longest measurement taken for every artifact provides preliminary information about the on-site and off-site transformation of stone tools. According to Weissmüller (1995:fig. 19), in theory, two ideal distributions for the frequency of the longest measurements of all artifacts of an assemblage can be distinguished.

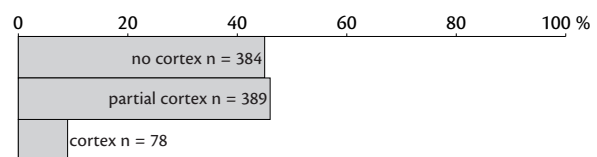

Figure 12-3—Frequency of cortex categories in Buran-Kaya III Level B1 (N = 851).

In the first, a normal (Gaussian) distribution, where most of the pieces are medium-sized, indicates an assemblage where cores and blanks, in most cases, were transformed only partly on-site. The weak representation of large flakes points to initial off-site reduction, such as decortication and core preparation. The fact that only a few small flakes and chips are present shows that the repeated preparation of striking platforms, as well as final flaking steps, such as the modification of blanks, also must have been conducted off-site. In the second, to the contrary, an exponential increase of small artifacts indicates an assemblage that was largely transformed on-site. With increasing numbers of flakes struck off a core or nodule, the longest measurement of the blanks decreases; as striking platforms are prepared very often, and blank edges are modified and resharpened, the number of small chips increases rapidly. All in all, 866 artifacts from Level B1 of Buran-Kaya III were measured, and the number of pieces in each mm class was counted. The interpretation of the diagram (Figure 12-4) needs caution, because all unretouched chips under 3 cm are missing in the measured sample. Between the largest artifact that measured 70 mm and artifacts measuring 32 to 30 mm, the graph shows an exponential growth towards small artifact sizes. In addition, Demidenko (Chapter 9) counted 4,241 chips between 29 and 15 mm, and 9,449 chips less than 15 mm. Thus, we can reconstruct an overall distribution of the longest measurements that is highly biased towards small artifacts and therefore fits well into Weissmüller's second model (1995:fig. 19 left). Combined with the data from the different cortex classes, we may conclude that considerable amounts of complete nodules were brought to Buran-Kaya III and decorticated, and that, at the same time, the assemblage was intensively reduced on-site.

How many nodules were imported? Were the imported nodules reduced until an exhausted core

was discarded, or were preforms and/or core blanks produced on-site and later exported? Did Neandertals from Buran-Kaya III carry any curated tools to the site, as was the case at European Middle Paleolithic sites (Geneste 1989; Weissmüller 1995; Richter 1997; Uthmeier 2000)? If so, what tool types did they prefer to carry while on the move? These questions need a more detailed analysis, which in this chapter is based on the sorting into raw material units.

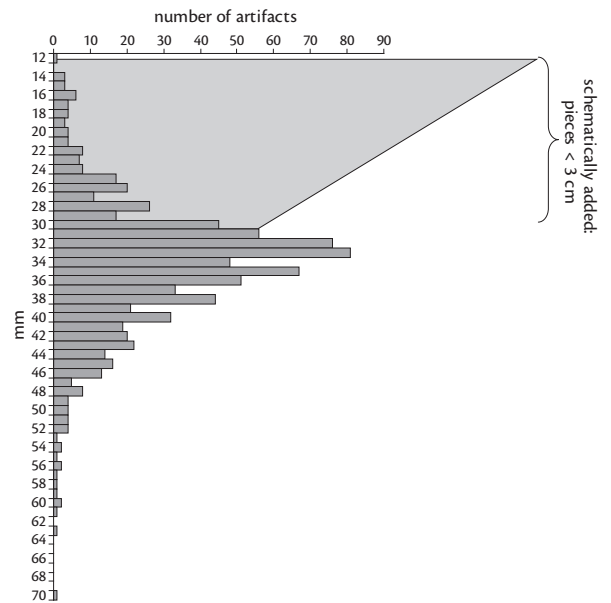

Figure 12-4—Longest measurements of all artifacts used for the transformation analysis from Buran-Kaya III Level B1. Because artifacts less than 3 cm were only considered when retouched, the sample is biased towards artifacts greater than 3 cm. The shaded area shows chips < 3 cm counted by Demidenko (cf. Table 12-1).

Raw Material Units and Procurement Strategy

Raw material units are defined by a combination of macroscopic attributes, such as the structure and the color of the fracture, the color and structure of the cortex, and the presence or absence of microfossils. Under the premise that the sorting looks for unique combinations, raw material units (RMUs) fall into one of four classes:

- (1) single pieces with only one artifact that shares no raw material attributes with any other artifact from the analyzed assemblage;
- (2) workpieces with two or more artifacts that are thought to belong to a single nodule;
- (3) raw material sources with two or more artifacts that belong to different nodules, but fall

- within the variability of attributes observed in nodules from a known raw material source;
- (4) formations with two or more artifacts whose provenance can only be traced back to the geological genesis.

Although other qualities were listed above, the sorting attempts to recognize as many raw material units as possible that equal either single pieces or nodules. After initially excluding 13,690 unretouched chips less than 3 cm in size, 49 patinated artifacts, and 610 heavily burned pieces, 866 artifacts with an overall weight of 4,228 grams remained for the attempt to find distinct nodules.

In total, 115 raw material units were distinguished (Figure 12-5). Because contact with fire did not lead to fissures or breakage, but to a change of color, the artifacts of one raw material unit with 15 artifacts had to be excluded. Fifty-nine raw material units fulfill the criteria for workpieces: each of them is thought to include only artifacts from a distinct nodule, each imported, possibly as different shapes, into the site and then flaked to different extents. Forty-five raw material units are single pieces that must have been imported as individuals and discarded on-site. Altogether, single pieces and workpieces interpreted as isolated episodes and, like refits, mirror physical and social activities of humans account for 90.4% of all raw material units. For 10 units, it remained unclear whether they represent single nodules or belong to more than one nodule from the same source. This uncertainty is often the result of many shared attributes, but slightly different cortex, or the presence of more than one core or preform within the same unit.

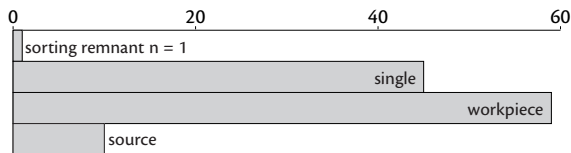

Figure 12-5—Classes of sorting into raw material units. Single pieces are unique in the sample and workpieces represent individual nodules, comparable to refits.

In the rich primary raw material sources of Crimea, the shape of the raw nodules is often diverse (Demidenko, Chapter 9; Uthmeier, Chapter 11). Especially when foliated surface-shaped tools, like leaf points, were produced, a preference for flint plaquettes has been described in some Paleolithic industries (e.g., for Buran-Kaya III Level C: Marks and Monigal 2000a:217). If raw material units include cores with cortex, cortical flakes, or blanks with partial cortex, it may be possible to determine the original shape of the flaked nodule. For the Level B1 material, three different shapes were distinguished: round nodules, round-but-flat nodules (sometimes also called flat pebbles: Marks and Monigal 2000a:217), and plaquettes (Figure 12-6). Fifty-nine raw material units, including many single pieces, did not allow a meaningful classification of the original nodule shape. Among the remaining, there are 35 round-but-flat nodules, 12 round nodules, and 9 plaquettes. Obviously, flat-but-elongated pebbles were preferred. Combined, they make up 78.6% of all reconstructed shapes for raw nodules.

Another simple, but instructive, attribute that facilitates recognition of certain preferences in the raw material procurement of Level B1 Neandertals is the

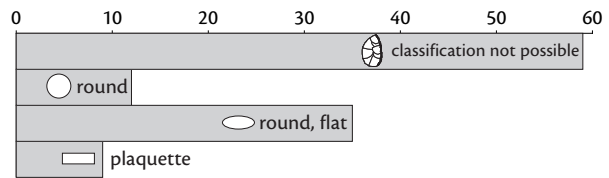

Figure 12-6—Shape of nodules for 115 raw material units. Classification was not possible in cases where artifacts with cortex were absent.

appearance of the cortex (Figure 12-7). Chalky cortex that can easily be wiped away is seen as an indicator for primary raw material sources. Cortex that is thin but can be scratched is correlated with secondary residual raw material sources, where the embedding limestone disappeared due to chemical or physical destruction and the more resistant flint nodules remained. If the cortex is heavily rolled and cannot be removed, or has been totally washed away, it is concluded that the pebble came from a river terrace. For 39 raw material units that had artifacts without any cortex, classification was impossible. Where classification was possible, 49 nodules came from primary sources, while 27 nodules were taken from residual sources. At first glance, the total absence of raw material collected from river terraces is amazing, for exploiting river terraces is the simplest strategy of raw material procurement. However, besides the fact that river terraces often only bear pebbles of poor quality, our own survey confirmed that the river bed of the Burulcha River is, at least for a distance of 5 km from the site, free of any siliceous material of a suitable size for flaking.

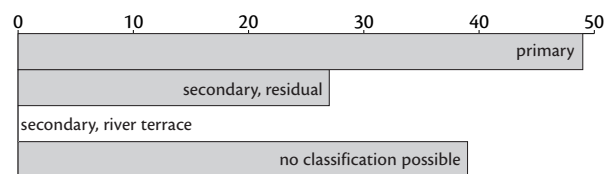

Figure 12-7—Classification of the cortex of 115 raw material units in reference to geological origin.

The attributes used here to describe the raw materials that were brought into the rockshelter of Buran-Kaya III do not provide clear evidence for their provenance. Most of the outcrops of primary Cretaceous flint known so far from eastern Crimea are supposed to belong to the same geological formation that came to the surface at different places. In addition, many outcrops sampled by us were quite diverse in the shape of the raw nodules, and sometimes also in the color of the fractures. The fact that the variability in color of the fractures is limited, and ranges, in most cases,

from dark brown to dark grey, points to the outcrops of Tsvetochnoye and Russakovka, some 10 to 15 km north of Buran-Kaya-III. Here, dark grey nodules of different shape were found at the base, whereas brown flints appeared towards the top of the profiles.

There are exceptions, however. Among the raw material units, we recognized a single piece (Kurbjuhn, Chapter 14: RMU 96) made of a reddish-brown flint that is unique in its black streaks and its white translucence. Surprisingly, we found this exotic raw material not only in Buran-Kaya III Level B1, but also, with little variance in the color, in Starosele Level I and in Chokurcha I Level I, also as single pieces.

What we can learn from our analysis of simple raw material attributes about Neandertal behavior is

Natural Loss or Artifact Transport by Neandertals? N-Transforms and C-Transforms in the 1996 Level B1 Sample

As noted above, 866 unpatinated artifacts from the 1996 excavation of Level B1 were sorted into 115 raw material units. Apart from one unit with burned artifacts, 114 (= 851 artifacts) of them were recognized as single pieces (45 RMUs), distinct nodules (59 RMUs), or as units where it was not clear if they represented distinct nodules or more than one nodule from the same raw material source (10 RMUs). Figure 12-8 shows the number of raw material units for classes of artifact frequencies. The number of artifacts in the raw material units ranges from a minimum of 1 piece (single pieces) to a maximum of 45 pieces (workpieces). The median of the distribution is 5 pieces per unit, showing that one-half of the raw material units include 1 to 5 artifacts only. In general, the mainly low frequencies of artifacts in raw material units emphasize the high resolution of the sorting. The fact that many units classified as “source” also have only between 2 and 14 artifacts, can be used as an argument that they also represent workpieces, in this case, with a more diverse cortex of the nodule. According to Weissmüller (1995:69), it is more likely that two or more Middle Paleolithic flakes from the same nodule reflect on-site reduction of cores, rather than that they were produced off-site and imported. Although this view might be too dogmatic, and some workpieces with low frequencies of tools might also relate to importation, it still must be asked why there are so many units with only a few artifacts in them. A superficial answer is banal: because many nodules are incomplete. What is the source of that incompleteness, however? Does it go back to C-transforms (Schiffer 1989), where the Neandertals took a nodule or preform to the site, struck off only a few flakes, and then exported the core, preform, or the surface-shaped

that they preferred a direct exploitation of primary sources, and that they more often chose flat pebbles or plaquettes. In other words, we see preferences in the selection of certain qualities and shapes. Furthermore, the fact that the raw material acquisition tends to follow a visible strategy that looked for good quality flat nodules and plaquettes reinforces the assumption that the Neandertals who came to Buran-Kaya III knew that there was a local shortcut to any siliceous materials. Because they *planned* their visits to Buran-Kaya III, they were able to choose preferred raw materials in advance and, if they had not passed a region where rich primary raw materials of the desired quality were available, they must have collected the nodules during micro-moves in the vicinity of a previous campsite.

tool together with simple blanks? Or, to the contrary, did N-transforms (Schiffer 1989) reduce the original number of artifacts in workpieces? And finally, were missing artifacts discarded nearby, but outside of the excavated area?

First of all, the data used here is biased towards artifacts larger than 3 cm. In the sense of Weissmüller (1995:67–68), chips of small size are static objects that fall down after their detachment. According

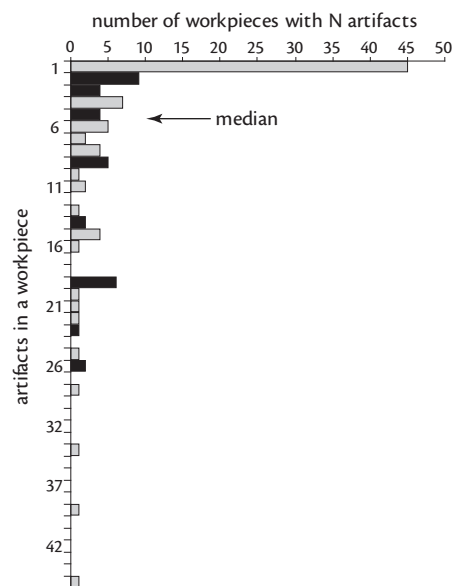

Figure 12-8—Frequency of raw material units in classes of artifact numbers. Most raw material units consist of one single piece only (top), the most numerous raw material unit (RMU) consists of 45 artifacts (bottom). Black bars include RMUs classified as “source.”

to the numbers given by Demidenko (Chapter 9), unretouched chips <3 cm account for 90% of the assemblage. In the well-preserved Magdalenian concentrations of Marsangy (Schmider and Croisset 1995: table 2) where long blades were flaked, the number of chips and waste from flaking less than 5 cm in size ranges between 64% (*amas 21*) and 49% (*amas K19-20*). On the living floors of the Micoquian G-layers of Sesselfelsgrotte, with an on-site production of surface-shaped tools such as flat handaxes or bifacial knives, the proportion of chips ranges between 60% and 80% (Richter 1997:86–117). These examples of well-preserved sites illustrate that the number of static objects clearly indicates an in situ preservation of, at least, most square meters of Buran-Kaya III Level B1 excavated in 1996. As a consequence, we have to add unknown numbers of simple chips under 3 cm to the artifacts sorted into each raw material unit. The frequency of chips in the G-layers of Sesselfelsgrotte permits the assumption that especially high numbers of chips occur when surface retouch is used to produce preforms for typologically bifacial tools (Boëda 1995b: *biface supports*). In the framework of the transformation analysis, this means that raw material units where surface retouch indicates the production of bifacial tools or bifacial preforms, the occurrence of only a few pieces larger than 3 cm is a more realistic value than it appeared on first glance.

Nevertheless, it is still an open question whether N-transforms and/or C-transforms were active after the deposition of the artifacts. Taking into consideration that the sedimentation rate was generally low, and that the thickness of Level B1 is approximately 20 cm (whereas excavations at other sites like Kabazi II saw archeological horizons measuring only 2 to 5 cm), it is very probable that the assemblage analyzed here is a mixture of several visits by Neandertal groups. According to a comparison of Levels B and B1, the activities during many of these visits tend to be similar in terms of tool and blank frequencies. High numbers of faunal remains (Patou-Mathis, Chapter 8) and artifact densities reaching an average of no less than 2,500 pieces per square meter (Demidenko, Chapter 9) speak for the intensity of these visits. It is assumed that, together with weathering, the movements of humans on the Pleistocene surface might have destroyed a considerable number of fireplaces, the remains of which are thought to be responsible for the characteristic dark color of the sediments in Level B1. Other data suggest that a restricted amount of space was used during these repeated visits. Profiles published so far (Marks and Monigal 2000a:fig. 2) show that the sediments of Level B1 form a depression. This depression may have led to today's spatial distribution not only because finds were trapped in it, but also because the depression may have been a preferred structure for activities of humans near the warmth of the rockshel-

ter's backwall. Within the spatial distribution for the artifacts of the transformation analysis sample, squares that mark the maximum artifact frequencies are found in the center of the 1996 excavations (Figure 12-9: Д8, Г7, Г8). From there, the density of finds declines dramatically towards the backwall and, less markedly, towards the borders of the excavations.

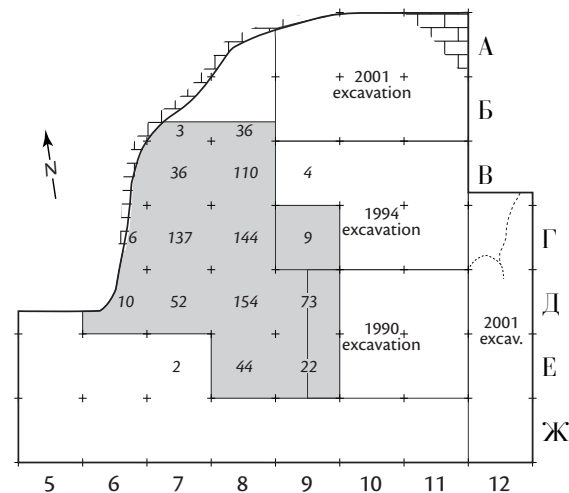

Figure 12-9—Artifact densities (artifacts > 3 cm and retouched chips) in squares of the 1996 excavation (shaded). Decreasing artifact densities speak for one more or less complete concentration.

While this distribution gives the impression of a unique, homogeneous concentration that might have been cut at its edges and, therefore, incomplete due to erosion (Demidenko, Chapter 9) and excavation area size, the detailed mapping of the spatial distribution of raw material units (Kurbjuhn, Chapter 14) proves the opposite. For workpieces, it is still possible to recognize single episodes of flaking. Many distributions of artifacts that come from a single nodule show a maximum in one square or two neighboring squares, and a decline towards one direction (see for example Kurbjuhn, Chapter 14: RMU 2, RMU 3, RMU 4, RMU 10, RMU 13, RMU 16, RMU 41, RMU 46). A spatially limited distribution, surrounded by decreasing artifact densities, is exactly what we can expect when areas where nodules or cores were flaked are preserved in situ. The maximum density marks the place where the knapping originally took place, and declining artifact densities result from the discard of waste products (Boëda and Pelegrin 1985:figs. 11 and 12). In contrast to the cited experiment, where these areas tend to be small and measure only 2 to 3 m², the spots in Buran-Kaya III Level B1 have been stretched by human movements on the living floor. Natural movements of artifacts was minimal, since most arti-

facts are neither rolled nor patinated, but show fresh and sharp edges.

That the overwhelming number of the maximum artifact densities within workpieces are situated fully inside the 1996 excavation area leads to the assumption that the sample used here is in situ, untouched

by severe N-transforms, and is representative of the activities that were conducted by Neandertals on-site. In other words, low artifact frequencies in the workpieces of Buran-Kaya III Level B1 mainly result, apart from the exclusion of simple chips under 3 cm in size, from import or export by humans.

When Raw Material Becomes Expensive: the *Chaîne Opératoire*

The technological repertoire of Level B1 was analyzed by looking at 65 raw material units classified as workpieces or raw material sources (Figure 12-10; compare also this chapter, “Results of the Transformation Analysis II: On-Site Production”). Comparable to refits, they are seen as sub-assemblages that resulted from the reduction of single nodules or cores. In contrast to conventional approaches, where artifacts are compared within techno-typological categories, this method allows a view of entire sequences of the *chaîne opératoire*. Because many details of the *chaîne opératoire* for Level B1 are found in Demidenko (Chapter 9), it is described here only very briefly, according to different phases of the *chaîne opératoire*.

PHASE 0, RAW MATERIAL ACQUISITION

The strategy of raw material procurement has already been described in detail above: flat pebbles or plaquettes from primary sources of Cretaceous flint were preferred.

PHASE 1, DECORTICATION, AND PHASE 2, BLANK PRODUCTION

Fifteen artifacts were classified as cores. However, it is not clear whether these were originally considered as sources for conventional blank production. They do not follow Levallois, Quina, or discoidal concepts, neither are they volumetric cores. While some of them have deep negatives that resulted from hard hammer technique, for others, classification of the flaking technique is difficult to determine. Nevertheless, we are convinced that apart from one core that was obviously used as an alternative source for some flakes, all other cores must be classified as preforms for surface-shaped tools that were discarded because of hinge fractures, bad flaking angles, etc. Among the blanks, some thick flakes, detached off-axis and completely or partially covered by dorsal cortex, were flaked by soft hammer technique (Figure 12-10: 1). It is probable that the primary flaking of flat pebbles transformed into surface-shaped blanks or tools began with the removal of these thick *déjeté* flakes. Other flakes of this form, however, were detached with a direct, hard hammer technique (Figure 12-10: 2). No fewer than 259 flakes

resulting from surface retouch were recognized by their narrow flaking angle, their lipping, a curved longitudinal section, and typical dorsal scar patterns with thin scars of previous surface detachments. Some of the platforms were carefully faceted, others were also abraded before the blow. They indicate an intensive production of surface-shaped, in most cases bifacially retouched, plano-convex blanks.

PHASE 3, MODIFICATION

Taking into consideration that prepared cores following any conventional concept in the sense of Boëda et al. (1990) are missing, it becomes obvious that modified blanks in Level B1 often came from the initial flaking of preforms for surface-shaped tools (Figure 12-10: 1-2). In addition, intensive use of flakes from surface retouch as blanks for unifacial tools (Figure 12-10: 3) gives the impression that raw material was sparse. In 32 of 65 workpieces, or 49.2% (Table 12-3, transformation sections Np to Nm/surface), that reduced nodules or preforms, a part of the waste of surface shaping served as blanks for tools (Figure 12-13).

Since Boëda's (1995b) analysis of the Micoquian levels of Külna cave, it has become obvious that the surface shaping of nodules and blanks is an alternative concept to the conventional production of blanks from prepared cores. He showed that the same working edges appeared both on simple flakes and on bifacial *biface supports*. The advantage that Boëda saw in bifacial blanks was the possibility of a recurrent resharpening of working edges, especially when they were, as at Külna, plano-convex/plano-convex. In contrast to simple blanks, where the retouch of the modified edges tends to become steeper when repeated and, finally, is in danger of hinge fractures, the angles of surface-shaped (bifacial) blanks remain stable. As a consequence, surface-shaped tools were recognized as artifacts with long life histories that often, like scraper reduction sequences (Dibble 1995), cross the borders of typological categories (Richter 1995:203-206, Chapter 13).

While this concept is widely known, we have documented another example of a similar use of simple blanks and surface-shaped *biface supports* in Level B1 of Buran-Kaya III. It is not based on the desire for

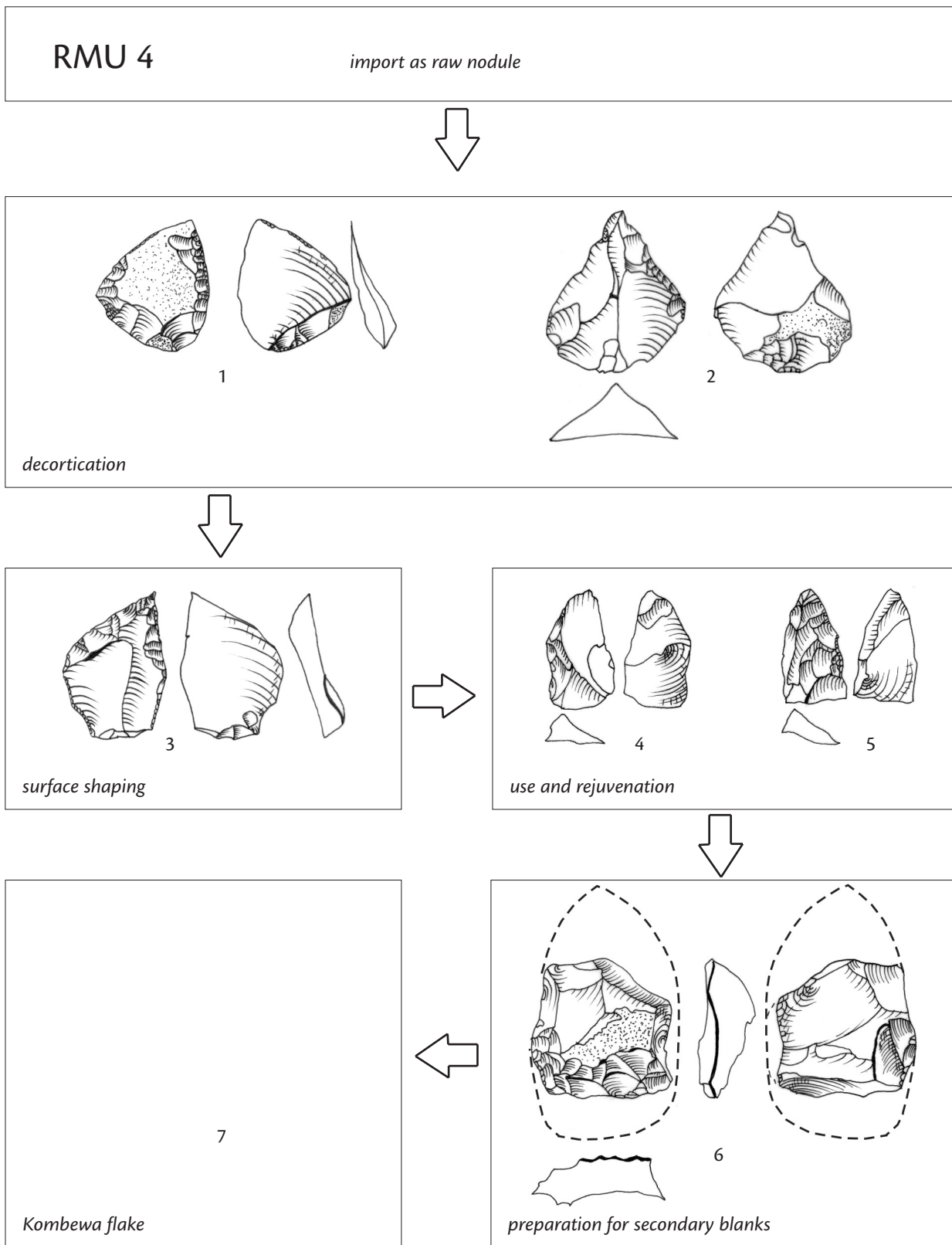

Figure 12-10—Raw Material Unit (RMU) 4’s artifact classification by major phases of the *chaîne opératoire*. Because they show a unique combination of raw material attributes, it is concluded that all artifacts belong to the same nodule; missing pieces are either less than 3 cm or were exported.

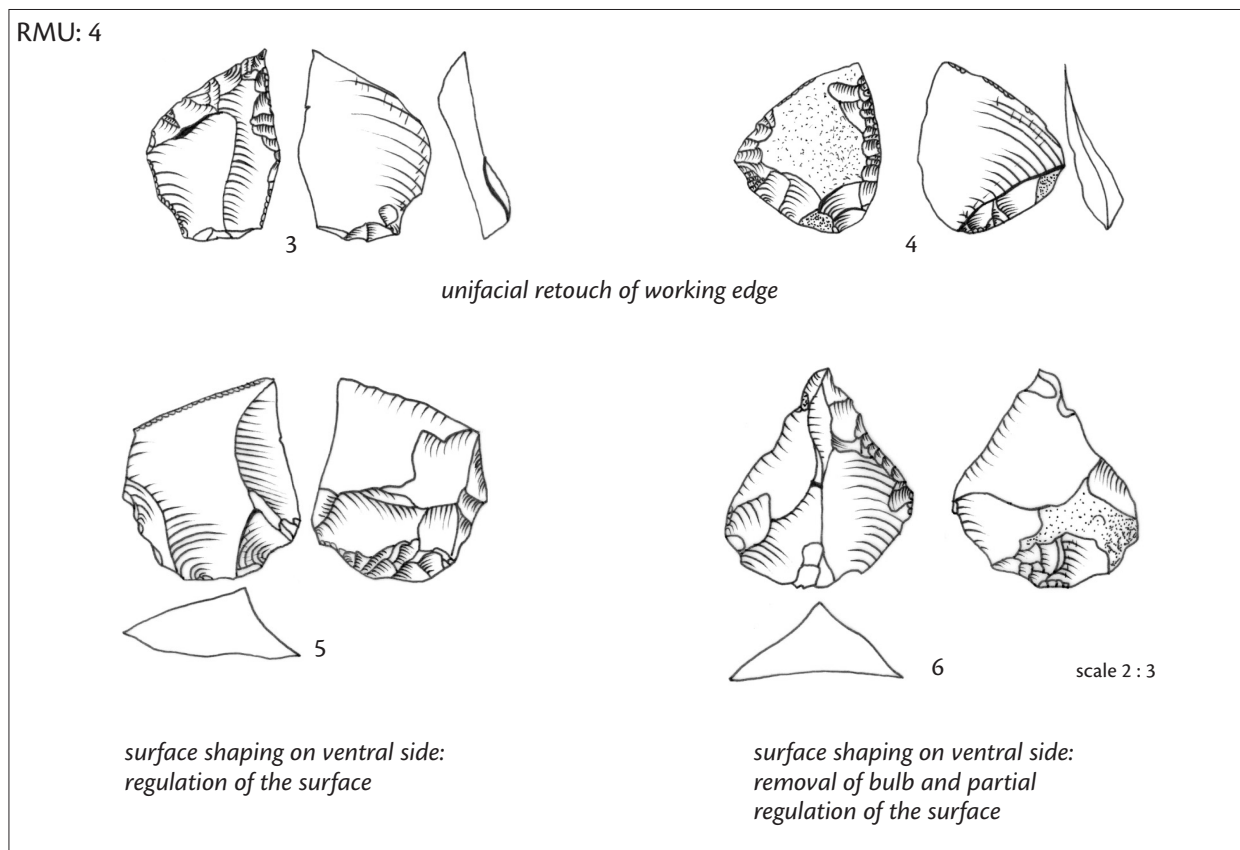
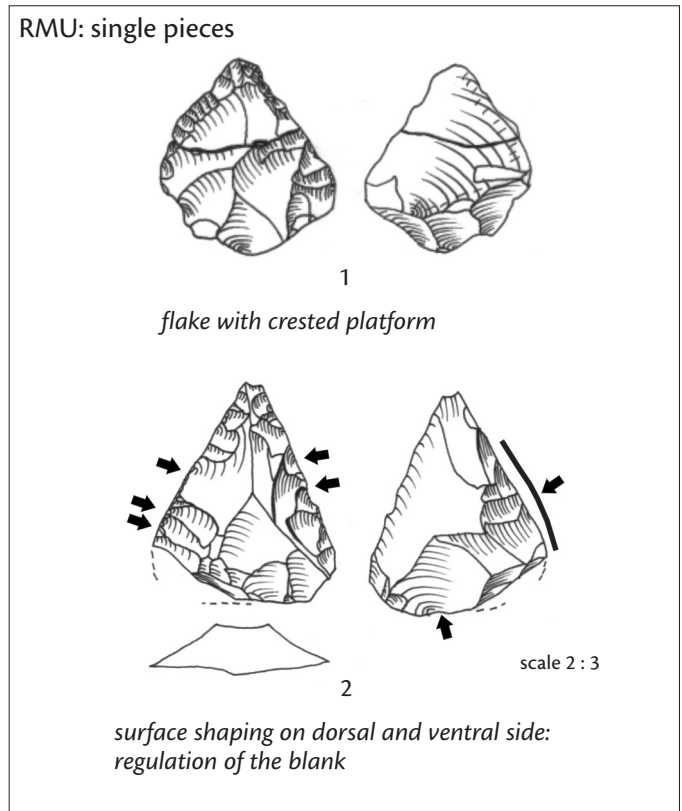
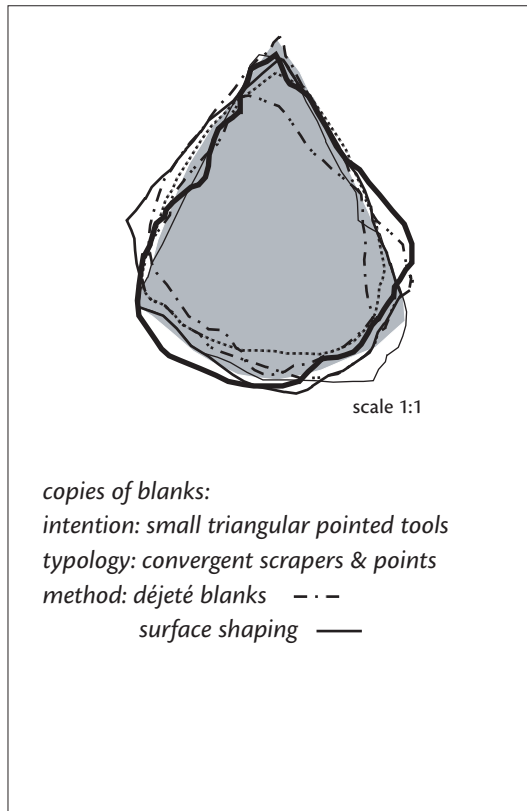
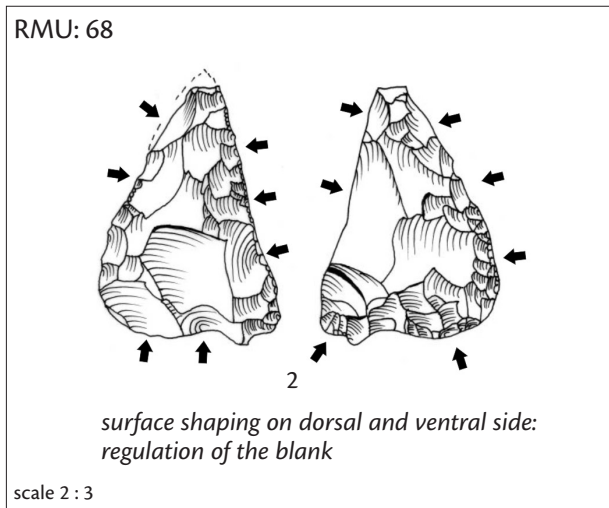
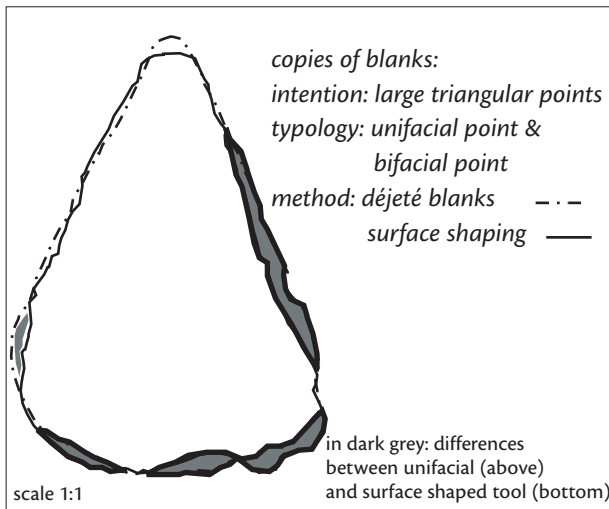
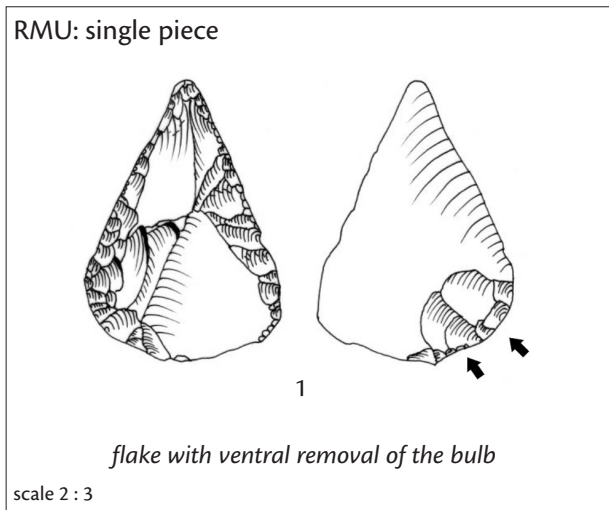

Figure 12-11—Small triangular pointed blanks that result from different methods of production. Identical outlines of simple tools and surface-shaped (bifacial) tools speak for surface shaping as an alternative strategy for the production of desired blank types. *Biface supports* are not the result of long tool life histories, but due to re-tooling and re-hafting processes.

1
2
3
4
5
6
7
8
9
10
11
12
13
14
15
16
17
18
19
20
21
22
23
24
25
26
27
28
29
30
31
32
33
34
35
36
37
38
39
40
41
42
43
44
45
46
47
48
49
50
51
52
53
54
55
56
57



51
52
53
54
55
56
57

Figure 12-12—Large elongated triangular pointed blanks that result from different methods of production. Identical outlines of simple tools and surface-shaped (bifacial) tools speak for surface shaping as an alternative strategy for the production of desired blank types. *Biface supports* are not the result of long tool life histories, but due to re-tooling and re-hafting processes.

long and diversely lived working edges. Instead, it is caused by a need for blanks with identical outline, length, and width measurements. Two triangular blank types, a smaller one with its greatest thickness near the butt (Figure 12-11), and a more elongated one (Figure 12-12), seem to have been of pronounced importance. For small triangular blanks, some simple blanks fit into the outline that was desired (Figure 12-11: 1, 3, 4). Others needed additional ventral thinning (Figure 12-11: 5), a complete surface shaping of the ventral surface (Figure 12-11: 6), or dorsal and ventral shaping (Figure 12-11: 2) to make them bifacial blanks. Based on technique of blank production and the number of modified working edges, these artifacts fall into different type categories: simple sidescraper (Figure 12-11: 4–6), convergent scraper (Figure 12-11: 1), unifacial point (Figure 12-11: 3), and bifacial point (Figure 12-11: 2). All of these pieces have nearly identical outlines (Figure 12-11). This is also true for two elongated triangular blanks that were modified into a point (Figure 12-12: 1) and a bifacial convergent scraper (Figure 12-12: 2). Whereas the first tool only needed the removal of the bulb via additional ventral thinning (Figure 12-12: 1), the second had to be reduced to a certain extent, since large ventral scars show that the piece originally was bigger. Only intensive surface shaping led it to have the same outline as its unifacial twin (an analysis of the complete operational sequence of this piece is found in Richter, Chapter 13). Because several tool classes, including simple scrapers, are involved, one simple explanation must be rejected: from our point of view: it is not very probable that a metrical standard for the discard of heavily used tools led to the observed metric similarities. It seems more plausible that the lack of a conventional blank production called for this strategy. Because prepared cores were missing, the needed blank form had to be achieved by alternative methods.

For the Micoquian assemblage of Lichtenberg, similar observations have already been made, but only for surface-shaped foliates that sometimes show amazing similarities in their outlines (Veil et al. 1994:33–35). The fact that some foliates from Starosele Level 1 also have identical outlines (Marks and Monigal 1998: fig. 7-17:c,d,f) can be taken as another example for the assumption that the production of exact copies was a widespread phenomenon in the production of bifacial tools in the Crimean Middle Paleolithic. To us, the hypothesis that surface-shaped tools are one-to-one copies of simple blanks, was new. On the other hand, such behavior is closely related to ventral thinning, a strategy that is supposed to be necessary during re-tooling and re-hafting when the bulb does not fit into the shaft (Mellars 1996:fig. 4.14). In general, use-wear analyses have proved that hafting was well known in the Crimean Middle Paleolithic (Kay 1999:170; Hardy et al. 2001). In Level B1 of Buran-Kaya III, there are

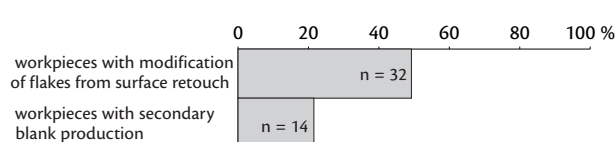

Figure 12-13—Selected technological features of the *chaîne opératoire* in 65 workpieces with blank production, as percentages.

also macroscopic arguments for it. In RMU 68, a bifacial convergent scraper (Figure 12-12: 2) shows a large, hinge-terminated dorsal scar at the base, that was employed as a final thinning of the piece after the edges were modified. Like the tiny retouch at the basal part of the lateral edges of the point (Figure 12-11: 3), a scar at the base of the previously described bifacial convergent scraper (Figure 12-12: 2) may have resulted from lateral damage while the pieces were moving in a haft (Shea 1989). Detailed analysis of the operational steps of selected surface-shaped tools from Level B1 (Richter, Chapter 13) also came to the conclusion that bifacial tools were re-sharpened while still hafted (Andrefsky 1998:figs. 2.17, 2.18).

PHASE 4, USE

Forty-eight tool tips indicate intensive use of retouched pieces. Some of them result from breakage after constant pressure, while others were clearly struck off by an intentional, controlled blow either from the side (Figure 12-10: 5) or directly on the ventral surface (Figure 12-10: 4). Thus, the latter have to be classified as waste from rejuvenation. No less than 71 resharpening flakes were counted, pointing to heavy use of working edges. At the moment, use-wear analyses are needed to decide whether the waste from lateral tool rejuvenation was re-used as a tool afterwards. In the Saalian Middle Paleolithic site of La Cotte de St. Brelade (Callow and Cornford 1986), use-wear analysis showed that lateral sharpening flakes were indeed used as tools after they were detached. For this cave on the Pleistocene seashore, a correlation between a lack of raw material and high frequencies of lateral sharpening flakes was explained in terms of an alternative blank production strategy after the rising sea level covered local raw material outcrops (Cornford 1986).

PHASE 5, DISCARD, OR: BACK TO PHASE 2, SECONDARY BLANK PRODUCTION

The ratio calculated for retouched formal tools and unretouched pieces greater than 3 cm (Table 12-1) is 1 : 3. If irregular retouched pieces are also taken into account (Table 12-1), the ratio is 1 : 2. It follows that the percentage of modified and therefore intensively used

blanks is very high. Use-wear analysis on unretouched pieces (Beyries 1987:103; 1988) confirms that simple retouch often marks only the end of the life history of stone artifacts with cutting edges. In Biache-Saint-Vaast (Beyries 1988) for example, only 5% of a sample that included both retouched and unretouched pieces showed no traces of use wear. Especially when a soft material, like fresh meat, is worked, traces of use-wear only develop after a considerable amount of time (Veil et al. 1994:54–58; Schütz et al. 1990:251). Experiments (Schütz et al. 1990:251) proved that the primary butchering of *Dama dama* can be carried out with only three simple flakes. Thus, it is possible that the ratio between used artifacts and pieces discarded without use was even higher than the above calculations suggest, based on retouched tools only. In Buran-Kaya III Level B1, a heavy duty usage of surface-shaped bifacial tools that resulted in broken tool tips was also observed. It can only be assumed that these artifacts indicate secondary butchering, such as on-site bone breakage to extract marrow. The analysis of Richter (Chapter 13) gives further information on the use of surface-shaped tools. It is concluded that they were hafted. Their discard, as well as the surface-shaped copies of simple blanks, must be seen as traces of re-tooling and re-hafting processes.

Although the *chaîne opératoire* has already been described as an intensive use of blanks and formal tools, there are several workpieces that exhibit another method used to avoid an early discard of raw material volume. A simple method was the use of a ventral side as a flaking surface. Five Kombewa flakes prove that this method was part of the technological knowledge of Neandertals from Level B1. What needs to be explained is the several blanks that were struck along prepared crests: 4 crested blades, 4 off-axis points each with a partly crested lateral edge, and 9 pseudo-Levallois points. A detailed analysis of the operational steps of an abandoned bifacial shaped tool (Figure 12-14) from RMU 4 (Figure 12-10: 6) led to the hypothesis that Kombewa-flakes might have also been flaked from exhausted bifacial pieces and unacceptable preforms. The earliest operational step (Figure 12-14: 2 step 1) was dedicated to plano-convex surface shaping. Large ventral scars of the plan surface retouch show that the piece must have been much larger at the beginning of its reduction. Two bifacial tool tips from the same nodule also support this observation (Figure 12-10: 4, 5). According to the logic of transformation analysis, the second tool tip indicates the former presence of a second bifacial tool, manufactured after the nodule was intentionally broken into two pieces at the very beginning of its reduction. The tool tips confirm the hypothesis that the analyzed piece originally was used as a bifacial tool before it became a bifacial Kombewa core. Perhaps during the time of use, perhaps afterwards, the piece was broken at its proximal

RMU: 4

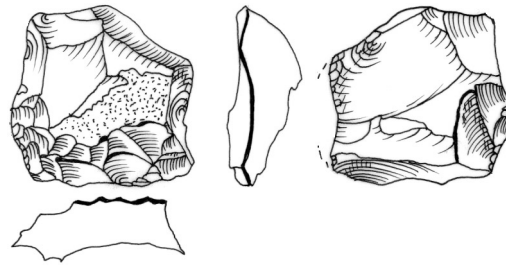

1. observation: core from workpiece 4

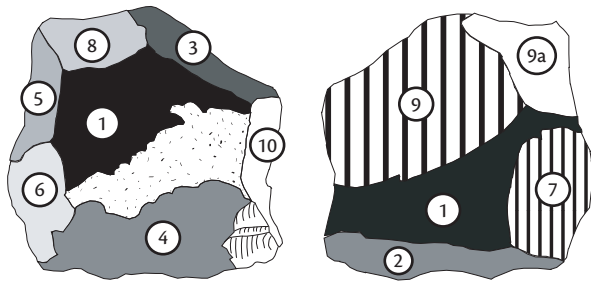

- 1 plano-convex surface shaping
- 2 intentional (?) breakage
- 3 crested blade
- 4 removal of chips (platform: 3)
- 5 creation of a platform
- 6 preparation of platform for 7
- 7 removal of chips (for lateral convexity (?))
- 8 preparation of platform for 9
- 9a creation of lateral convexity for 9
- 9 removal of thick hard hammer (target-) flake
- 10 intentional breakage (for creation of platform?)

2. analysis of operational steps

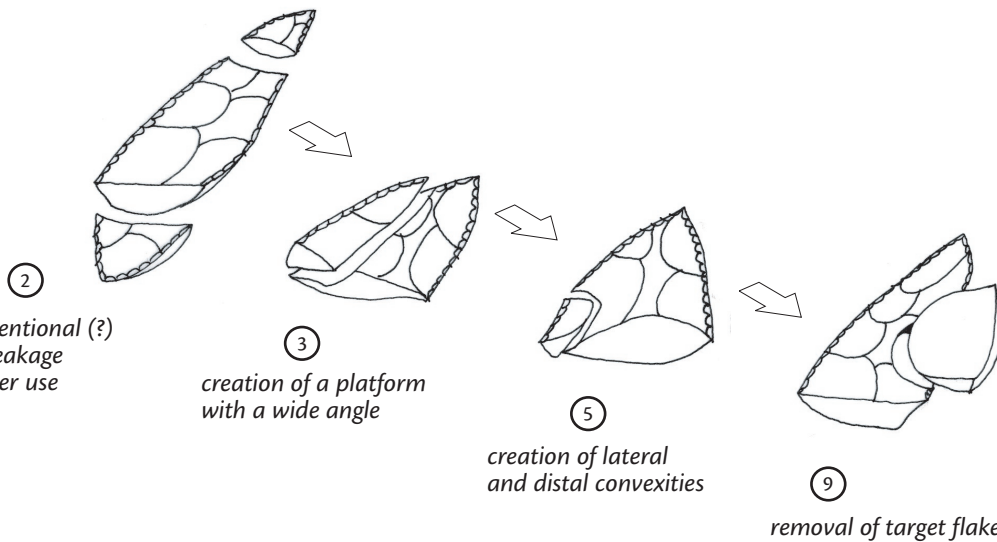

3. hypothesis: generalized *chaîne opératoire*
(Kombewa) flake production from exhausted surface-shaped preforms or tools

Figure 12-14—Secondary blank production from exhausted bifacial tools and unacceptable preforms. The method is similar to the Kombewa method, but produces flakes with a dorsal scar pattern that shows negatives of surface shaping instead of a (second) ventral surface.

end (Figure 12-14: 2 step 2). This might also have happened at the distal end that is now covered by scars of later operational steps. These later operational steps include the detachment of a crested blade (Figure 12-14: 2 step 3) and some chips that prepared platforms for the flaking of the ventral surface (Figure 12-14: 2 steps 5, 6, and 8). If they were found on a prepared core, scars on the ventral surface would have been classified as preparation of distal (Figure 12-14: 2 step 7) and lateral convexities (Figure 12-14: 2 step 9a) for the knapping of a target flake (Figure 12-14: 2 step 9). At the end, the exhausted bifacial core was intentionally broken with a ventral blow near its right lateral edge (Figure 12-14: 2 step 10). Aware that it is often difficult to distinguish conventional debitage from by-products from the surface shaping of bifacial tools, we still do not think that our Kombewa flakes (Figure 12-10: 7) fall into the variability of failed removals from the ventral retouch of plano-convex bifacial tools (Boëda 1995b) and, therefore, are simply by-products of surface retouch. For three reasons, we are convinced that they represent a last attempt to maximize the overall output from the reduction of exhausted bifacial tools or broken preforms. First, the described operational steps occurred at the very end of the biography of the piece. Second, several final, yet logical, operational steps do prepare the last flake, rather than trying to rescue the former bifacial blank. Third, we have the impression that a hard hammer technique was used and that these flakes are too thick for plano-convex surface shaping. From 65 (Table 12-3: transformation sections Np to Nm/surface) workpieces related to core production, surface-shaped preforms, or surface-shaped tools, 14 (21.5%) show secondary blank production of this kind (Figure 12-13). Finally, it must be stressed that these observations remain reasonable, if hypothetical, until refits are found.

A Reflection upon the Classification of Transformation Sections: Debitage and Surface Shaping

Transformation analysis classifies workpieces (e.g., artifacts from single nodules) according to the number of phases of the schematic *chaîne opératoire* (Weissmüller 1995:58–71) that can be reconstructed on-site (for more details see Uthmeier, Chapter 11). Based on the discarded artifacts, the sequence that was conducted on-site is called the transformation section (Weissmüller 1995:58: *Transformationsausschnitt*). The length of the transformation section is measured by the presence of artifacts that are defined as indicative for certain operational steps (e.g., cortical flakes for decortication). Some workpieces might represent all operational steps of the *chaîne opératoire*, while oth-

Because workpieces are comparable to refits, artifacts of the same workpiece, at least in Middle Paleolithic times, were made by the same person. Since all technological aspects described above accumulate in single workpieces, as in RMU 4 (Figure 12-10 and Kurbjuhn, Chapter 14), it must be concluded that the complete *chaîne opératoire* was part of the technological knowledge of the Neandertals that visited Buran-Kaya III. Therefore it is highly likely that these Neandertals were adults.

To avoid the need for new raw material supplies, the Neandertals of Level B1 used a set of technological strategies to optimize the output of the *chaîne opératoire* from a given amount of raw material for working edges and standardized tools for hafting. At the same time, they successfully minimized useless waste. The following list summarizes the most characteristic features of the *chaîne opératoire*:

- (1) The use of thick cortical flakes and of thin flakes from surface retouch, both derived from the production of surface-shaped blanks, for simple tools.
- (2) In cases where suitable blanks could not be found, blanks of secondary quality were prepared by thinning and surface shaping for re-tooling and re-hafting processes.
- (3) For resharpening purposes, the terminal ends of points and convergent scrapers were removed.
- (4) Lateral sharpening flakes were detached mainly for rejuvenation, and perhaps as alternative blanks for cutting.
- (5) Bifacial artifacts were resharpened while fixed in the haft.
- (6) Exhausted surface-shaped tools or preforms of lesser quality were used as cores for the controlled detachment of thick flakes (secondary blank production).

ers might have reached the site as single pieces only. Sometimes, intermediate operational steps and/or phases of the *chaîne opératoire* might be missing, as well. By following the logic of transformation analysis, it is possible to reconstruct the qualitative presence of other artifacts not actually found on-site. In part, it is also possible to reconstruct their numbers and add them to the sample. Beforehand, it is not known whether N-transforms, small excavation areas, or C-transforms led to the observed incompleteness (Weissmüller 1995:71: *Evakuation*). Only in situ and completely excavated concentrations allow the conclusion that missing artifacts are the result of importing

and exporting by humans. In these cases, the transformation analysis allows an insight into segments of human movements within the landscape.

Originally, the classification of transformation sections proposed by Weissmüller (1995:58–71; see also Uthmeier, Chapter 11) was developed for unifacial Mousterian assemblages. We have seen, however, that the *chaîne opératoire* used at Buran-Kaya III Level B1 (and many other assemblages of the Crimean Micoquian) is dedicated to the production and modification of surface-shaped tools, and at the same time makes intensive use of by-products from this primary production sequence. To avoid the invention of new classes for transformation sections that include, for example, the production of a surface-shaped blank, its modification into a bifacial tool, and the use of by-products of this surface retouch for modified pieces, only the presence or absence of surface retouch is indicated by the suffix *.surface (Figure 12-15). This classification is only given for the process of surface shaping itself. In other words, as soon as there are

indications for the use, modification, or production of a bifacial tool, the conventional classes are extended with *.surface. On the other hand, single pieces that are made on flakes from surface retouch are treated conventionally (e.g., Bw or Tw). This is done because the process of production of surface-shaped blanks (decortication, primary flaking, surface retouch) is considered to be initially dedicated to the use of a surface-shaped (often bifacial) tool, rather than to the production and use of its by-products. Figure 12-15 sums up the modifications we added to Weissmüller's classification of transformation sections. Furthermore, it illustrates that the point at which surface shaping can be recognized within the reduction sequence is, to some extent, floating. For flint plaquettes, for example, surface retouch is often established from the beginning. Round pebbles, on the other hand, may be decorticated with a hard hammer technique and identified as simple ad hoc cores if discarded before surface retouch was applied (transformation sections Np or Nb).

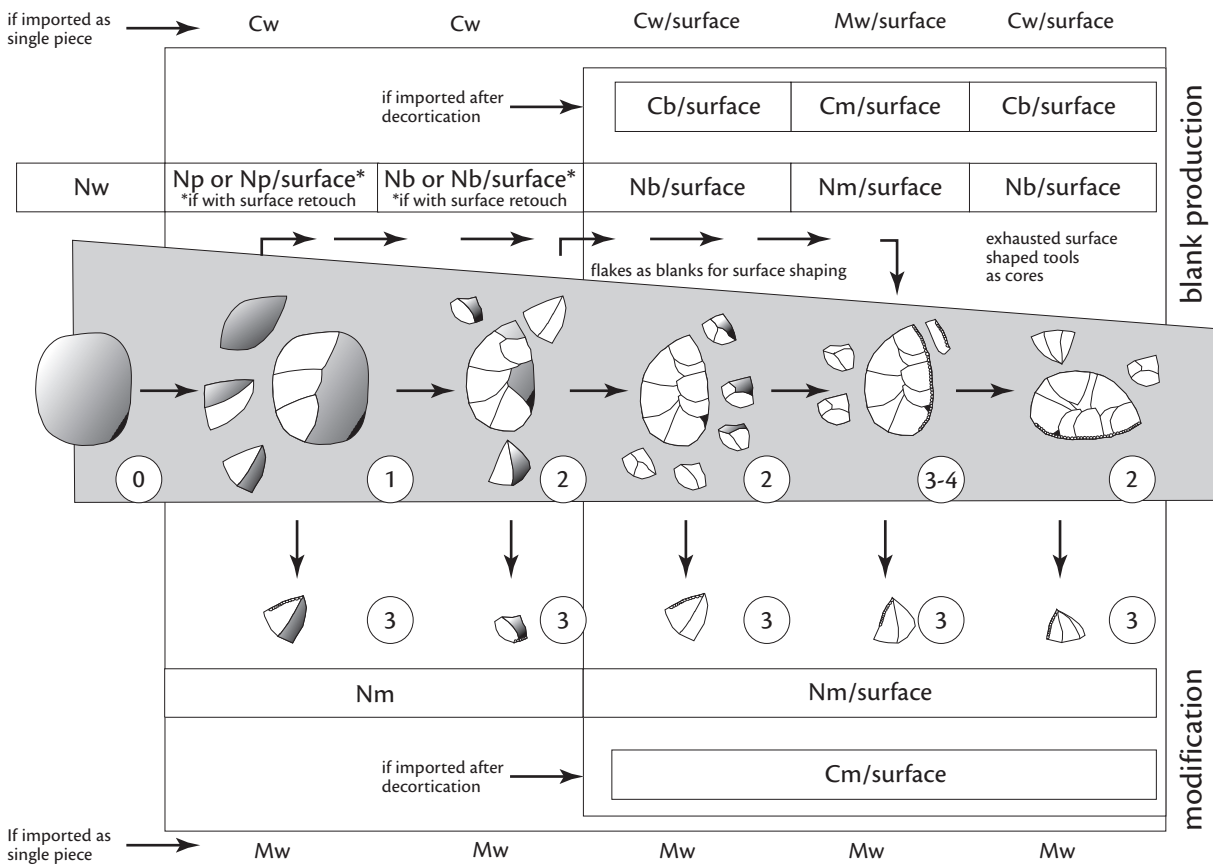

Figure 12-15—Classification of transformation sections for raw material units with surface shaping (defined as the production of blanks with surface retouch), modification of by-products, and/or secondary blank production: *w*—single piece without other artifacts, *p*—preparation only, *b*—blank production, *M/m*—modification, *T*—tool, *N*—RMU was imported as nodule, *C*—RMU was imported as core, *surface*—surface shaping on-site.

Transformation Sections in Buran-Kaya III Level B1: an Overview

The data for the transformation analysis comes from 114 raw material units (Figure 12-16) that are described in detail in a separate catalogue (Kurbjuhn, Chapter 14). Before starting, it is important to stress that the analysis of single pieces and workpieces leads to significant results, no matter if Level B1 is the equivalent of one visit or, as it seems more probable, of several visits. Like refits, workpieces reassemble the original context of sub-assemblages, which all contain contemporaneous artifacts.

Forty-five raw material units are single pieces (Figure 12-16 and Table 12-3: transformation sections Bw to TT). According to the demands of our sorting, each single piece in this sample is unique in its combined macroscopic raw material attributes. By definition, blanks for single pieces were not produced from nodules, preforms, or cores of the analyzed sample. For several reasons discussed above, we are of the opinion that it is permissible to suggest most of these single pieces were not only detached outside the area excavated in 1996, but at some other, yet unknown, sites. These sites may include previous sites near the raw material sources, as well as contemporaneous sites within the local site territory (Higgs and Vita-Finzi 1972:30) of Buran-Kaya III.

Thirty-four (29.8%) single pieces were classified as artifacts discarded without any further on-site flaking.

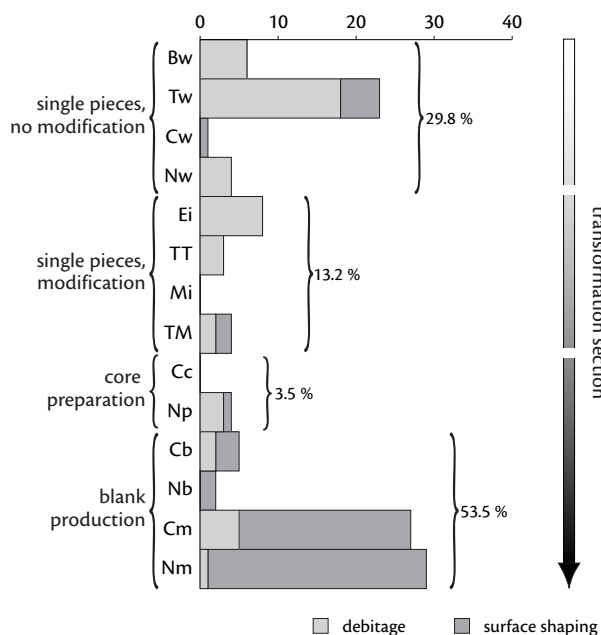

Figure 12-16—Classification of transformation sections for 114 raw material units. Each bar shows the total number of raw material units classified as such (in dark grey: RMU with surface shaping “*facial”).

This group of imported artifacts that were only used, but not resharpened, on-site is dominated by 15 simple tools and 5 surface-shaped bifacial tools (Figure 12-16 and Table 12-3: transformation section Modification without or Tw). Six flakes (Figure 12-16 and Table 12-3: transformation section Blank without or Bw), 4 nodules (Figure 12-16 and Table 12-3: transformation section Nodule without or Nw), and 1 core (Figure 12-16 and Table 12-3: transformation section Core without or Cw), complete the artifacts that were discarded without on-site flaking.

Another 11 single pieces are blanks and tools that were imported, but more intensively used (transformation sections Ei to TM). From 8 simple tools, only isolated tool tips or waste from rejuvenation remained at the site, while the tool itself was exported afterwards (Figure 12-16 and Table 12-3: transformation section isolated End of a tool or Ei). Another 3 simple tools broke during use, but a fragment was taken away (Figure 12-16 and Table 12-3: transformation section Tool Fragment or TT).

In four cases, a blank was modified after import, and both the tool and the waste of the modification were discarded on-site (Figure 12-16 and Table 12-3: transformation section Tool modified or TM).

In sum, raw material units that include artifacts with flaking during use, but without blank production, include 15 (13.2%) items. Altogether, 5 surface-shaped tools (Figure 12-16: Tw), 2 surface-shaped preforms (Figure 12-16: TM), 11 simple tools (Figure 12-16: Ei, TT), 1 core or preform (Figure 12-16: Cw), 8 blanks (Figure 12-16: Bw, TM), and 4 nodules (Figure 12-16: Nw) were imported and discarded without any or only minor flaking. The remaining 65 (57%) raw material units were dedicated to the production of blanks (transformation sections Cc to Nm). While 33 started with a nodule, 32 began with imported cores or surface-shaped preforms. The reduction not only started, but also ended at different stages of the *chaîne opératoire*.

Following the analysis of the *chaîne opératoire*, there were mainly surface-shaped tools that resulted from the flaking of either raw nodules or already decorticated and/or prepared preforms. The classification of the latter depends on the absence (then: cores) or presence of traces of surface retouch (then: surface-shaped preforms—transformation sections with extension *.surface). The production sequence of 4 raw nodules (3.5%) stopped after initial preparation (Figure 12-16: Np). In 61 (53.5%) raw material units, the lithic reduction went further. In 7 cases, however, no formal tools occurred and only blanks remained at the site (Figure 12-16: transformation sections Core with blanks or Cb, Nodule with blanks or Nb). Because no cores or surface-shaped preforms were found in these workpieces

(Table 12-3: RMU 23, RMU 66, RMU 26, RMU 58, RMU 32, RMU 38, RMU 57), there must have been export of the latter artifact categories. For 27 out of 54 raw material units with blank production and modification, flaking started with cortical flakes, indicating that raw nodules were brought to the site (Figure 12-16: Nodule with modified blanks or Nm). In 27 raw material units, the reduction sequences began with cores or surface-shaped preforms (Figure 12-16: Core with modified blanks or Cm). As far as formal tools are concerned, 48 raw material units saw the production and modification of a surface-shaped blank and/or the modification of by-products (Table 12-3: Cm/surface or Nm/surface), whereas the number of raw material units with only unifacial tools accounts for 6 items (Table 12-3: Cm or Nm).

The assumption that surface shaping dominated the blank production of Level B1 is strongly supported by the occurrence of flakes from surface retouch in most of the transformation sections (Figure 12-17). They were predominantly recognized in raw material units where blank production was observed either from partly or completely decorticated nodules (Figure 12-17: Cb, Cm) or from raw nodules (Figure 12-17: Nb, Nm). Flakes from surface retouch, however, are also found in raw material units classified as single pieces. If it is true that they were imported, then surface-shaped tools were also produced at previous

and/or contemporaneous sites, and by-products were imported from these sites as simple tools (Figure 12-17: Tw) or blanks (Figure 12-17: Bw). Because some single pieces were found at the border of the concentration of the 1996 excavations (Figure 12-19), it is also possible that some of these pieces were detached on-site, but not in the excavated area.

Figure 12-18 shows the overall percentage and number of cortical blanks, blanks partially covered by dorsal cortex, and blanks without dorsal cortex for each transformation section, separated by debitage from cores and surface shaping. Cortical blanks and blanks with cortex are numerous. This is true for single pieces (Figure 12-18: Bw to Nm and Nm/surface) and for sections indicating on-site blank production. Apart from those that are recognized by the presence of cortical and partially cortical flakes (Figure 12-18: Np, Np/surface, Nm, Nm/surface), there are transformation sections with blank production from pieces imported as cores (Figure 12-18: Cb, Cm) and bifacial preforms (Figure 12-18: Cb/surface, Cm/surface) that include 30% to 60% of partially cortical blanks. High percentages of blanks with cortex in transformation sections with surface shaping are explained by the main focus of the production process being the surface-shaped, often bifacial, tool. The reduction was stopped when the outline and cross-section reached the desired form. If, as in Buran-Kaya III, flat nodules

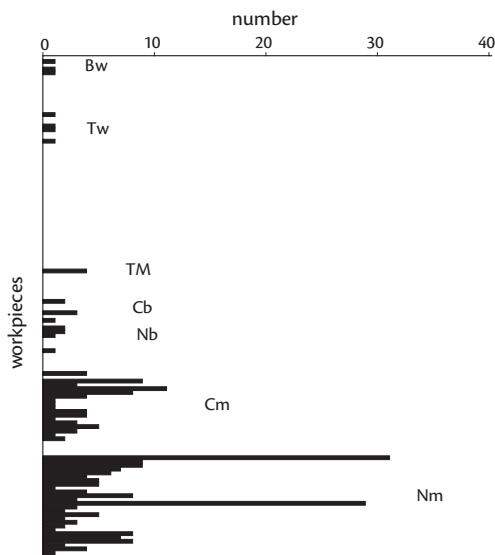

Figure 12-17—Frequency of flakes from surface retouch in 114 raw material units. Each bar indicates the number of flakes from surface retouch in a raw material unit. Transformation sections are grouped as: *Bw*—single blanks, *Tw*—single tools, *TM*—imported blanks modified on-site, *Cb*—on-site blank production from cores, *Nb*—on-site blank production from nodules, *Cm*—on-site blank production from cores and modification of blanks, *Nm*—on-site blank production from nodules and modification of blanks.

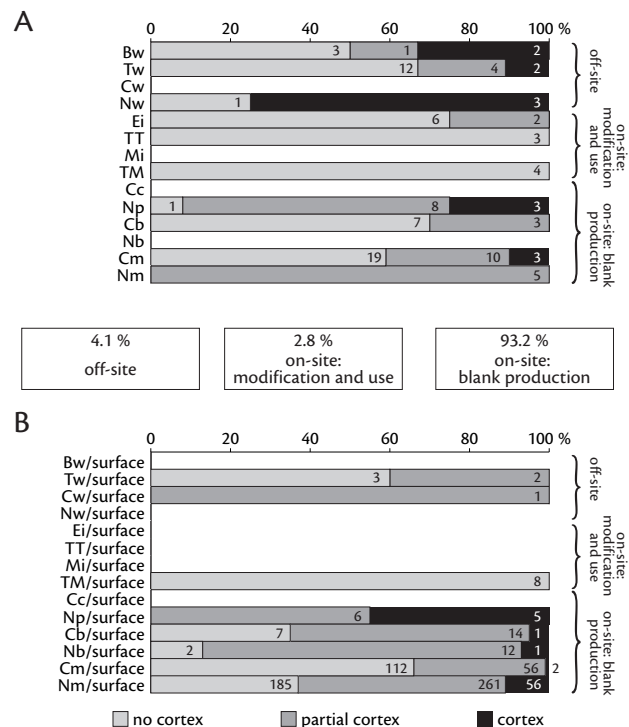

Figure 12-18—Cumulative percentages of different cortex categories in transformation sections without (A) and with (B) surface shaping. Numbers indicate frequencies of artifacts in transformation sections.

TABLE 12-3

Overview of occurrences and frequencies of artifact categories that lead to a classification of the transformation section

move to the site

	<i>Transformation section†</i>	<i>RMU</i>	<i>Number of artifacts</i>	<i>Weight</i>	<i>Import of raw nodule</i>	<i>Import of cores or surface shaped preforms</i>	<i>Import of simple tools</i>	<i>Import of surface shaped tools</i>	<i>Import of blanks</i>	
<i>Blank without flaking, discarded</i>	Bw	72	1	8	1	
	Bw	88	1	5	1	
	Bw	92	1	3	1	
	Bw	93	1	2	1	
	Bw	107	1	2	1	
	Bw	108	1	5	1	
<i>Tool without flaking, discarded</i>	Tw	42	1	18	.	.	1	.	.	
	Tw	69	1	46	.	.	1	.	.	
	Tw	70	1	21	.	.	1	.	.	
	Tw	74	1	20	.	.	1	.	.	
	Tw	76	1	10	.	.	1	.	.	
	Tw	77	1	12	.	.	1	.	.	
	Tw	78	1	3	.	.	1	.	.	
	Tw	80	1	5	.	.	1	.	.	
	Tw	83	1	4	.	.	1	.	.	
	Tw	86	1	5	.	.	1	.	.	
	Tw	87	1	2	.	.	1	.	.	
	Tw	95	1	3	.	.	1	.	.	
	Tw	96	1	5	.	.	1	.	.	
	Tw	97	1	18	.	.	1	.	.	
	Tw	100	1	24	.	.	1	.	.	
	Tw	110	1	2	.	.	1	.	.	
	Tw	112	1	1	.	.	1	.	.	
	Tw	114	1	1	.	.	1	.	.	
		Tw/surface	71	1	13	.	.	.	1	.
		Tw/surface	75	1	12	.	.	.	1	.
	Tw/surface	81	1	11	.	.	.	1	.	
	Tw/surface	90	1	5	.	.	.	1	.	
	Tw/surface	91	1	12	.	.	.	1	.	
	Cw/surface	105	1	10	.	1	.	.	.	
<i>Imported nodules</i>	Nw	73	1	16	1	
	Nw	79	1	19	1	
	Nw	84	1	7	1	
	Nw	101	1	8	1	
<i>Isolated edges, resharpened tool exported</i>	Ei	98	1	2	.	.	.	1	.	
	Ei	103	1	2	.	.	.	1	.	
	Ei	104	1	2	.	.	.	1	.	
	Ei	106	1	2	.	.	.	1	.	
	Ei	109	1	1	.	.	.	1	.	
	Ei	111	1	1	.	.	.	1	.	
	Ei	113	1	1	.	.	.	1	.	
	Ei	115	1	1	.	.	.	1	.	

1
2
3
4
5
6
7
8
9
10
11
12
13
14
15
16
17
18
19
20
21
22
23
24
25
26
27
28
29
30
31
32
33
34
35
36
37
38
39
40
41
42
43
44
45
46
47
48
49
50
51
52
53
54
55
56
57

TABLE 12-3 CONTINUED

Overview of occurrences and frequencies of artifact categories that lead to a classification of the transformation section

move to the site



	<i>Transformation section†</i>	<i>RMU</i>	<i>Number of artifacts</i>	<i>Weight</i>	<i>Import of raw nodule</i>	<i>Import of cores or surface shaped preforms</i>	<i>Import of simple tools</i>	<i>Import of surface shaped tools</i>	<i>Import of blanks</i>
<i>Tool fragment</i>	TT	82	1	4	.	.	.	1	.
	TT	99	1	2	.	.	.	1	.
	TT	102	1	11	.	.	.	1	.
<i>Modification only</i>	TM	7	2	16	.	.	.	1	.
	TM	89	2	10	.	.	1	.	.
	TM/surface	30	2	14	.	.	.	1	.
	TM/surface	65	6	21	.	.	.	1	.
<i>Preparation of nodule</i>	Np	1	7	66	1
	Np	62	3	17	1
	Np	67	2	21	1
	Np/surface	15	11	41	1
<i>Blanks from core</i>	Cb	23	4	9	1
	Cb	66	6	34	.	1	.	.	.
	Cb/surface	26	3	14	.	1	.	.	.
	Cb/surface	58	4	27	.	1	.	.	.
<i>Blanks from nodule</i>	Nb/surface	32	2	7	1
	Nb/surface	38	5	11	1
	Nb/surface	57	8	45	1
<i>Blanks, some modified, from imported cores or surface shaped preforms</i>	Cm	33	5	30	.	1	.	.	.
	Cm	35	2	15	.	1	.	.	.
	Cm	36	6	38	.	1	.	.	.
	Cm	39	4	16	.	1	.	.	.
	Cm	94	3	29	.	1	.	.	.
	Cm/surface	5	10	32	.	1	.	.	.
	Cm/surface	9	4	88	.	1	.	.	.
	Cm/surface	13	25	112	.	1	.	.	.
	Cm/surface	22	9	30	.	.	.	1	.
	Cm/surface	24	6	28	1
	Cm/surface	27	23	92	.	1	.	.	.
	Cm/surface	28	14	53	.	1	.	.	.
	Cm/surface	29	8	30	.	1	.	.	.
	Cm/surface	31	2	11	.	1	.	.	.
	Cm/surface	34	4	13	.	1	.	.	.
	Cm/surface	37	2	7	.	1	.	.	.
	Cm/surface	41	16	58	.	1	.	.	.
	Cm/surface	43	9	35	.	1	.	.	.
	Cm/surface	47	15	86	.	1	.	.	.
	Cm/surface	52	8	39	.	1	.	.	.
	Cm/surface	54	9	21	.	1	.	.	.
	Cm/surface	56	8	26	.	1	.	.	.
	Cm/surface	59	15	57	.	1	.	.	.
	Cm/surface	60	5	12	.	1	.	.	.
	Cm/surface	61	4	17	.	1	.	.	.
	Cm/surface	68	3	31	.	1	.	.	.
	Cm/surface	85	2	10	.	1	.	.	.

1
2
3
4
5
6
7
8
9
10
11
12
13
14
15
16
17
18
19
20
21
22
23
24
25
26
27
28
29
30
31
32
33
34
35
36
37
38
39
40
41
42
43
44
45
46
47
48
49
50
51
52
53
54
55
56
57

TABLE 12-3 CONTINUED

Overview of occurrences and frequencies of artifact categories that lead to a classification of the transformation section

move to the site

X transported

	<i>Transformation section†</i>	<i>RMU</i>	<i>Number of artifacts</i>	<i>Weight</i>	<i>Import of raw nodule</i>	<i>Import of cores or surface shaped preforms</i>	<i>Import of simple tools</i>	<i>Import of surface shaped tools</i>	<i>Import of blanks</i>
Blanks, some modified, from imported nodules	Nm	20	5	31	1
	Nm/surface	2	39	150	1
	Nm/surface	3	26	119	1
	Nm/surface	4	34	218	1
	Nm/surface	6	28	162	1
	Nm/surface	8	23	115	1
	Nm/surface	10	21	114	1
	Nm/surface	11	19	80	1
	Nm/surface	12	22	106	1
	Nm/surface	14	7	34	1
	Nm/surface	16	19	127	1
	Nm/surface	17	6	31	1
	Nm/surface	18	19	115	1
	Nm/surface	19	19	94	1
	Nm/surface	21	20	148	1
	Nm/surface	25	46	198	1
	Nm/surface	40	26	115	1
	Nm/surface	45	15	111	1
	Nm/surface	46	20	75	1
	Nm/surface	48	19	48	1
	Nm/surface	49	4	12	1
	Nm/surface	50	13	59	1
	Nm/surface	51	11	38	1
	Nm/surface	53	9	17	1
	Nm/surface	55	9	26	1
	Nm/surface	63	14	30	1
Nm/surface	64	15	78	1	
Total imported pieces									114
Formal tools discarded on site					38	29	19	20	8

†The following abbreviations for transformations sections are used in the table:

Chapter 11 provides a detailed definition of each.

Bw–Blank without debitage/modification

Tw–Modified without debitage/modification

Cw–Core without debitage/modification

Nw–Nodule without debitage/modification

Ei–isolated End of a tool

TT–Tool Fragment

TM–Tool modified

Np–Nodule prepared

Cb–Core with blanks

Nb–Nodule with blanks

Cm–Core with modified blanks

Nm–Nodule with modified blanks

*/surface–with surface shaping

TABLE 12-3 CONTINUED

Overview of occurrences and frequencies of artifact categories that lead to a classification of the transformation section

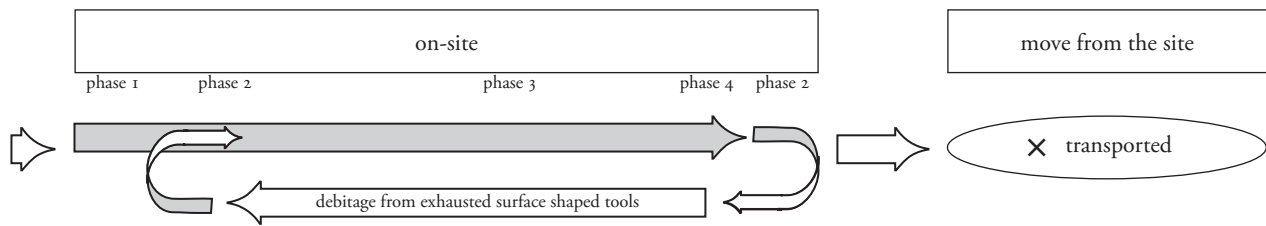

	phase 1	phase 2	phase 3	phase 4	phase 5									
<i>Discard without flaking</i>
<i>Decoritication</i>	3	3	12	4	2
<i>Simple blanks from debitage (or initial preparation of surface shaped tools)</i>	1	3	9	7	5
<i>Blanks from façonnage of surface shaped tools</i>	.	28	9	7	5
<i>From these are</i>
<i>Modification of blanks and/or discard of simple tools</i>	.	12	9	7	5
<i>Among simple tools: modification of flakes from surface shaping?</i>	.	x	x	x
<i>From these or/and from nodules, pre-forms, chunks</i>
<i>Modification of surface shaped blanks and/or discard of surface shaped tools</i>	.	.	1	3	2
<i>Use (tool-tips) or resharpening (resharpening flakes)</i>	1	5	4	7	4
<i>Among blanks: secondary flaking from exhausted surface shaped tools?</i>	.	.	.	x
<i>Discard of surface shaped preforms or cores after flaking</i>	2
<i>Export of cores (flakes, tools, core trimming elements left on-site)</i>	1
<i>Export of surface shaped preforms (= flakes from surface retouch left on site)</i>
<i>Export of surface shaped tools (blanks from façonnage/tool tip/resharpening left on-site)</i>
<i>Export of simple tools (resharpening chips, tool-tips, and/or fragment left on-site)</i>

	Total artifacts flaked and discarded on-site (Ei to Nm/surface)										807	Total exported artifacts			57
34	79	334	239	152	32	40	106	14	9	13	5	33	6		
23				152		40									

and plaquettes were the starting point, then high frequencies of partially cortical flakes must be expected. For transformation sections where flakes or scars from surface retouch do not occur and, for typological reasons, a reduction of imported cores must be assumed (Figure 12-18: Cb, Cm), the overall quantities of artifacts is low and tend to be unreliable for a percentage comparison. That among these low quantities of artifacts, many flakes with cortex do appear might be explained by the hypothesis that these cores, in reality, are partly decorticated preforms for surface-shaped tools, discarded after initial primary flaking with a hard hammer technique. If they were true, fully prepared cores, one would expect not only target flakes from some concept or method, but also many more flakes without cortex. Thus, the high percentage of partially cortical blanks in transformation sections that indicate the import of cores or preforms (Cb, Cb/surface, Cm, Cm/surface) implies a more or less direct transport from the raw material source to Buran-Kaya III. If there had been longer stays in between, then one would have to expect fewer blanks with cortex, since

they would have been detached, used, and discarded on the way to Buran-Kaya III. Adding the 29 raw material units identified as resulting from the reduction of imported raw nodules, it becomes clear that Neandertals came (several times) directly in one move of approximately 10–15 km from the outcrop or from a neighboring camp to Buran-Kaya III.

In this chapter thus far, the 114 raw material units, their classification, and their cortex frequencies have been discussed. What about the overall artifact frequencies (Figure 12-18)? The overall frequencies of artifacts are calculated for off-site blank production without on-site flaking, off-site blank production without debitage, but with modification on-site, and on-site blank production and modification. Of all discarded artifacts (851), a total of 794 (93.3%) were flaked on-site within 65 raw material units. In most cases, they were workpieces. Only 34 (4.1%) artifacts were brought as single pieces to the site and then immediately discarded. Of all artifacts, 23 (2.8%) came from 12 tools or blanks that were resharpened and/or modified on-site.

Spatial Distribution of Transformation Sections

Raw material units and their classification as transformation sections have mainly been discussed above without reference to their spatial distribution. It was noted that, in many cases, the distribution of artifacts from a raw material unit has a maximum areal extent of less than one square meter, with decreasing artifact densities in the neighboring square meters. This was interpreted as a sign of an in situ preservation of small areas of knapping that were enlarged by human movements on the occupation surface. Were there any areas with an accumulation of transformation sections that indicate special activities? Because transformation sections allow only interpretations in terms of the length of the *chaîne opératoire* conducted on-site, results of mapping of transformation sections are restricted to: (1) areas where single pieces and/or tools, nodules, and cores were abandoned after little (TM, Np, Cc) or no flaking (Bw, Tw, Cw, Nw, Ei, TT), indicating a zone of arrival; (2) areas where a production of blanks started from nodules or cores without reaching phases of surface retouch (Nb, Nm, Cb, Cm); and (3) areas where a more or less complete *chaîne opératoire* took place (Nb/surface, Nm/surface, Cb/surface). Or, conversely, did the proposed multiple visits lead to a homogeneous scatter of artifacts where no zones of activity could be recognized, at all? To answer these questions, the overall spatial distribution of transformation sections in square meters from the 1996 excavation is discussed below. The data set used here treats square meters as units and transformation sec-

tions as attributes. For each square meter excavated, the number of occurrences of different transformation sections was counted. In other words, because artifact frequencies are not included, the data are based on the unweighted maximal spatial distribution of each raw material unit, measured at the square meter level and classified as a specific transformation section.

A descriptive comparison of the distribution of 11 transformation sections is difficult and, so, single pieces were mapped together (Figure 12-19). The distributions of long transformation sections with surface shaping that indicate the production and modification of formal tools (Nm/surface, Cm/surface) and transformation sections that correlate with the discard of imported single pieces are widely spread. Both are characterized by high densities in the center of the excavated area. Nodules and cores that were classified as conventional debitage (Cb) or assigned to transformation sections without modification (Cb/surface; Nb/surface) are situated within the borders of this central concentration, but, at the same time, are less widely spread than those with an optimal, full length *chaîne opératoire*. This is explained as an early discard of conventionally flaked cores and nodules, or as resulting from unsuccessful attempts to produce bifacial tools (Cb). Compared to transformation sections with modification, a more restricted distribution of those without formal tools must be expected, because formal tools indicate a longer history and more intensive use than do unretouched blanks. Therefore,

Single pieces

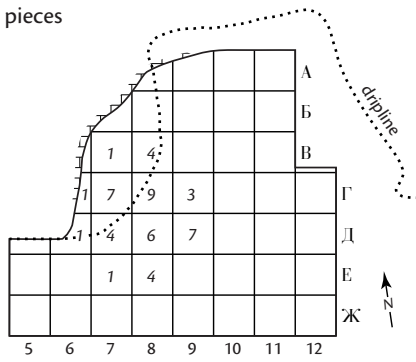

• TM
○ TM/surface

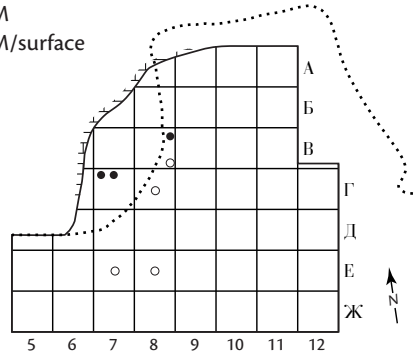

• Np
○ Np/surface

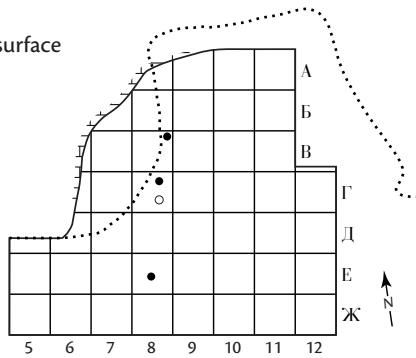

• Cb
○ Cb/surface

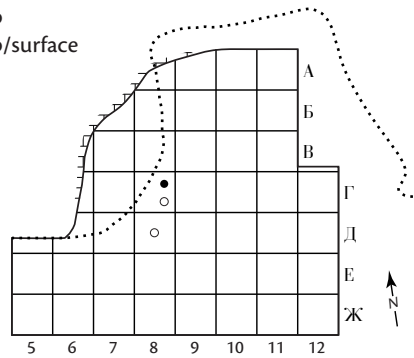

○ Nb/surface

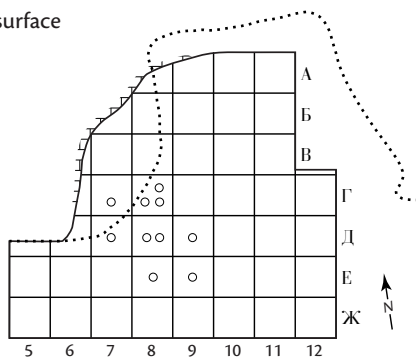

• Cm

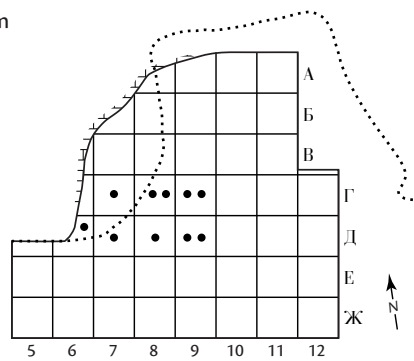

• Nm
- Nm/surface

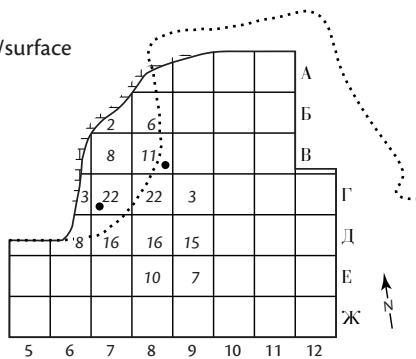

Cm/surface

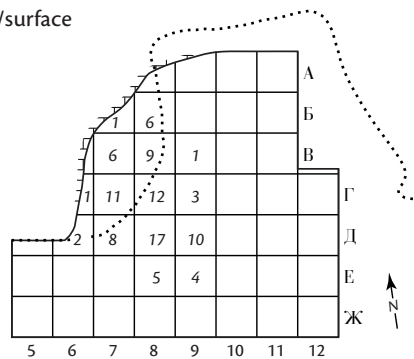

Figure 12-19—Distribution of transformation sections in the square meters excavated in 1996. Square meters are treated as units, the classification of transformation sections as variables. For example, 3 raw material units classified as “Cm” are found in 7 square meters, with different frequencies because the spatial distribution of raw material units sometimes overlaps.

formal tools are more often used at a considerable distance from the place where they were originally detached from the core.

The central concentration described above can be separated from areas at the northern and southern border of the excavated area where nodules were prepared (Np, Np/surface) and blanks were modified (TM). Thus, indeed, there seems to be a zone in the periphery of the center where short transformation sections are exclusively found.

For more secure results, the data discussed above were ordered statistically with a cluster analysis (shared nearest neighbor clustering, WinBasp-software, distance measure: Euclidean distance). Within the dendrogram (Figure 12-20), three clusters can be distinguished on the level of four neighbors considered. Because on this level no units are sorted into residue, it is chosen as the most appropriate ordering. The interpretation of the clusters follows the cluster statistics given in Table 12-4. It turns out that cluster 3 includes all transformation sections documented in the sample. That means that raw material units with both short and long life histories were discarded in square meters that belong to this cluster. At the same time, the entire *chaîne opératoire* was conducted here. The greatest emphasis lies on surface shaping. Clusters 1 and 2, however, are characterized by a decline in transformation sections. Still, the dominance of surface shaping is recorded throughout the clusters. The mapping of the results obtained from clustering (Figure 12-21: A) shows a coherent cluster, cluster 3, in the center of the

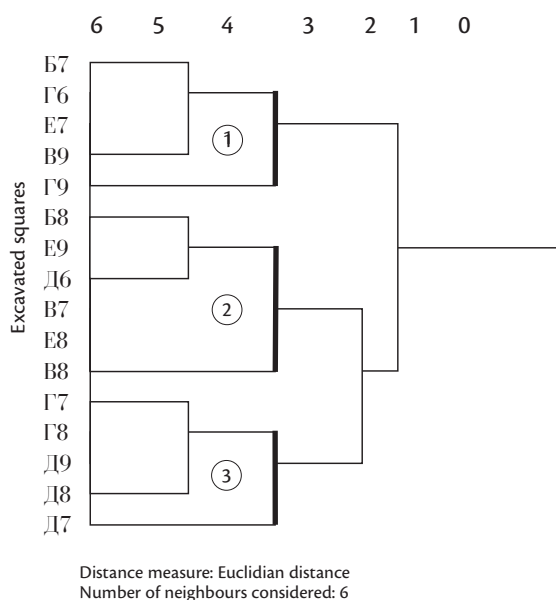

Figure 12-20—Results of a nearest neighbor clustering of transformation sections in square meters (1996 excavation) in a dendrogram. On the level of 4 nearest neighbors, 3 clusters can be distinguished.

excavated area. Its spatial distribution occupies an area that was recognized as a zone of maximum artifact densities (Figure 12-9). The other two clusters, clusters 1 and 2, are distributed in accordance to their similarity with cluster 3: cluster 2, in direct contact to cluster 3, and cluster 1 in its wider distribution.

The spatial distribution of the clusters is explained by simple artifact densities: where more artifacts were found, the more transformation sections occurred. With decreasing artifact densities, the number of transformation sections decreases as well. Taking into consideration, however, that the mapping of workpieces showed in situ knapping areas of single nodules often laying side by side or over each other, the clusters also mirror Neandertal's movements on the surface. In a kind of center and periphery mode (Figure 12-21: B), some artifacts were moved from the center of the concentration, where the main area of activity was, to the borders. It seems as if clusters 1 and 2 describe a kind of centrifugal movement, possibly caused by people leaving and entering the central activity zone. It must be noted that the ordering of the cluster analysis mainly reflects non-proportionately high artifact densities in the central zone of activity. Details such as small zones of arrival, recognized in the individual mappings of transformation sections, are not measured because the transformation sections involved do not have enough individual pieces to survive in the overall cluster analysis.

Both the mapping of artifact densities (Figure 12-9) and the analysis of the spatial distribution of transformation sections (as zones of activity: Figures 12-19 and 12-21) came to the same results: Buran-Kaya III Level B1 consists of a single concentration. From a general perspective, low artifact densities at the border of the concentration correlate with low numbers of transformation sections. This suggests intentional

TABLE 12-4

Statistical results of a nearest neighbor clustering of transformation sections in square meters (1996 excavation). Compared to cluster 3, clusters 1 and 2 show declining occurrences of transformation sections.

<i>type</i>	<i>Residue</i>	<i>Cluster 1</i>	<i>Cluster 2</i>	<i>Cluster 3</i>
TM	—		1	2
Np	—		2	1
Np/surface	—			1
Cb	—			1
Cb/surface	—			2
Cm	—	2	1	7
Cm/surface	—	6	32	58
Nm	—		1	1
Nm/surface	—	8	50	91
TM/surface	—	1	2	1
single	—	9	10	33

A

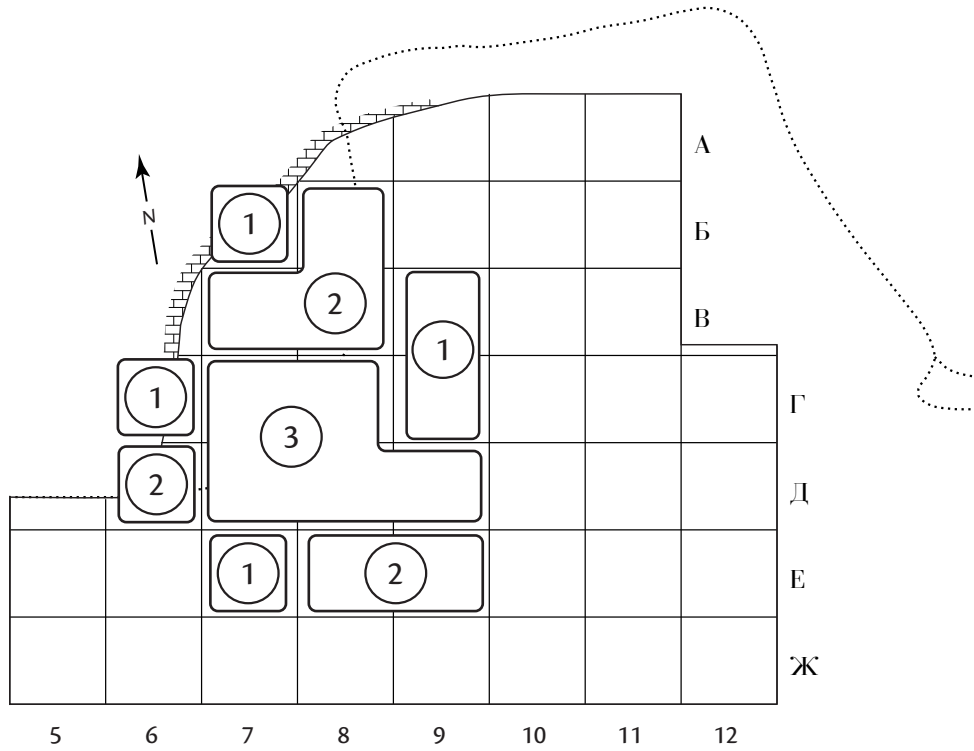

B

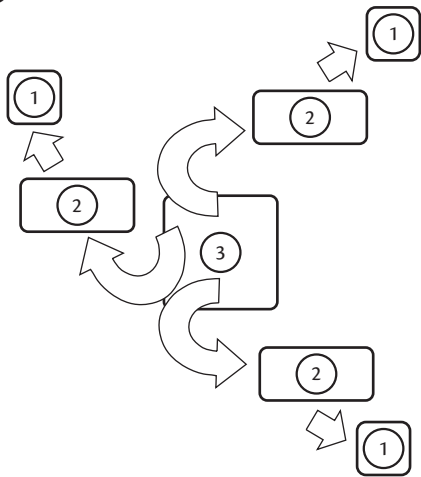

*overall interpretation:
centrifugal movements from center
to periphery of a single concentration*

C

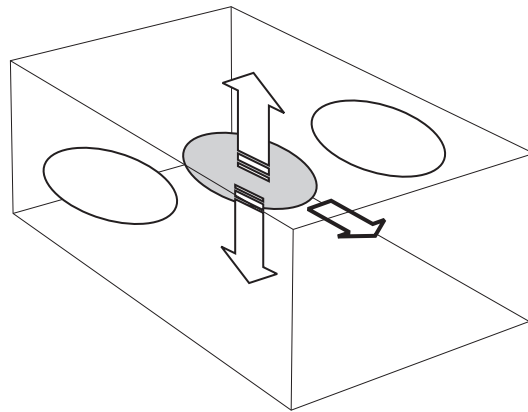

*detailed interpretation:
artifacts were vertically moved by N-transforms
and horizontally moved by C-transforms*

Figure 12-21—Spatial distribution of the results from the nearest neighbor clustering (A) shown in Figure 12-20, an overall interpretation (B) as movements into and out of a central zone of activity, and an interpretation of the movements of artifacts of a single raw material unit (C) resulting from N-transforms (vertical movements) and C-transforms (horizontal movements).

transport of tools (single pieces) and the unintended transport of simple blanks (long transformation sections) from center to the periphery. Because most of the workpieces individually mapped by Kurbjuhn (Chapter 14) clearly show zones where the knapping originally took place, an additional model of artifact movement and preservation must be sought. Why is it so difficult to subdivide the main concentration into different activities, while it is possible to isolate micro-activities that derive from the detachment of single workpieces within this concentration? Richter (1995:fig. 40) reconstructed the vertical and horizontal distribution of workpieces in the *éboulis-rich* sediments of the Micoquian G-layers of Sesselfelsgrötte as the result of artifact movement up and down in the course of N-transforms. The vertical depth where the maximum number of pieces occurred marked the stratigraphic position where the knapping originally

took place. Here, in Level B1 (Figure 12-21: C), it seems as if C-transforms, (e.g., movements caused by walking humans), must be added to Richter's model. However, the hypothesis that several repeated visits accumulated in the 20 cm-thick Level B1 cannot be rejected. There must have been some factor or factors, however, that averted a severe mixture of artifacts. Obviously, one was a minimal sedimentation that embedded each visit, separating it from earlier and later visits. Otherwise, it would have been impossible to recognize distinct knapping areas on the maps of the workpieces (Kurbjuhn, Chapter 14). Because artifacts were moved slightly up and down by N-transforms within the limits of Level B1, this was not visible during the excavations. In addition, the visits might have been less intensive than originally thought, and/or areas of activity might have changed from visit to visit within the center of the excavated area (cluster 3).

Results of the Transformation Analysis I: Import

Transformation sections are temporal sequences of the *chaîne opératoire*. (The basic data for the following analysis is shown in Table 12-3.) Each raw material unit represents such a temporal sequence. Some, like single pieces, are short and restricted to use only, while others went through a much longer sequence. All 114 raw material units, however, originally entered the concentration as a single artifact: for those discarded immediately (Bw, Tw, Cw, Nw) or shortly after their import (Tt, Np), the original blank is often easy to determine, whereas others were largely reduced or exported and their original blank has to be reconstructed. This is done with the help of discarded flakes and other by-products of their production. If, for example, many cortical flakes and partially cortical flakes are combined with a bifacial tool, then it can be concluded that a raw nodule was imported. If, conversely, only flakes without cortex were found, then a decorticated preform must have been the starting point for the reduction. As long as flakes are combined with cores, bifacial preforms, or surface-shaped tools, it is possible to recognize the initial artifact, even if the core, the bifacial preform, or the surface-shaped tool was exported. For single surface-shaped tools that reached the site in reduced shape, however, the blank often remains unknown.

A detailed list of the imported blanks is found in Table 12-3; Figure 12-22 illustrates the data in a diagram. While for some 13 blanks, the shape is undetermined, in part due to the export of the modified pieces after resharpening and in part due to complete bifacial retouch, it was possible to reconstruct the majority of imported blanks. Among those discarded on-site without flaking or after rejuvenation only,

simple flakes and flakes of surface retouch dominate with 11 items each. The occurrence of flakes from surface retouch has to be seen in combination with the fact that 4 surface-shaped tools made on flakes, and one bifacial tool made from an unknown blank are also found among the imported artifacts (Table 12-3: Tw/surface). Given the assumptions that (1) the provenance of the raw material must be 10 to 15 km to

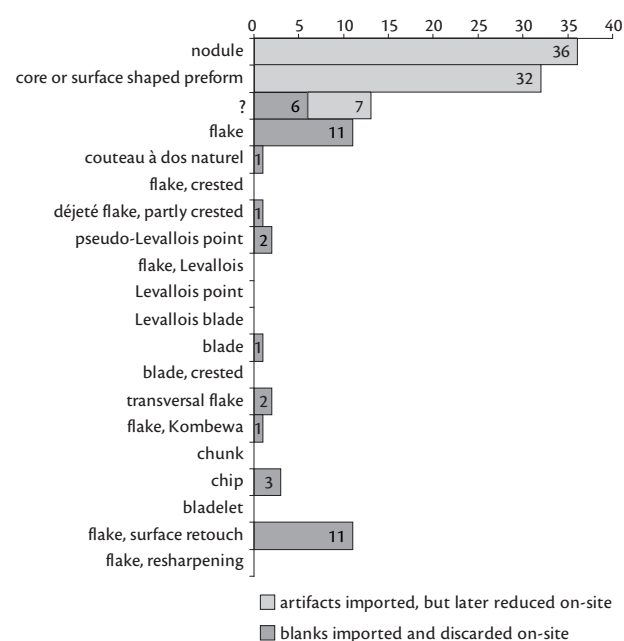

Figure 12-22—Frequencies of imported blanks due to discarded items (black bars) and reconstructed items. Raw material units flaked on-site were mainly imported as nodules, cores, or surface-shaped preforms.

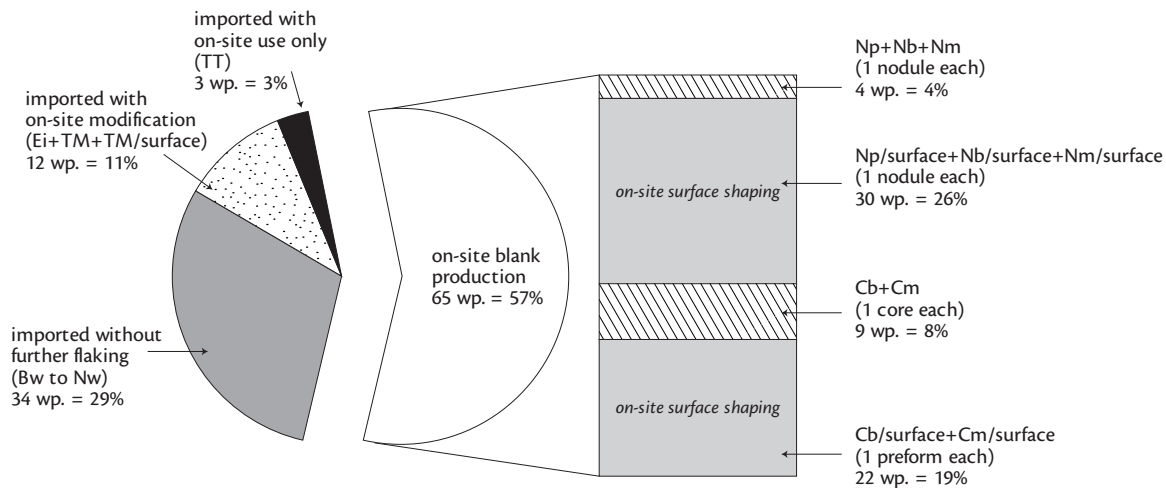

Figure 12-23—Biography of imported blanks. Slightly more than a half of all raw material units underwent intensive flaking on site (right), mainly for the production of surface-shaped (bifacial) tools or preforms.

the north and (2) that imported artifacts were generally transported within one move, it is certain that a *chaîne opératoire* similar to the one described for Level B1 existed at places where the imported blanks were produced. The fact that some blanks were detached along prepared (crested) edges does not necessarily suggest the presence of prepared cores. As has been shown for the *chaîne opératoire* of Buran-Kaya III Level B1, the import of 1 partly crested *déjeté* flake, 2 pseudo-Levallois points, and 1 Kombewa flake may also derive from a *chaîne opératoire* dedicated to the production of surface-shaped tools. However, it is interesting that together with 3 transversal flakes, some more voluminous blanks were chosen for a move to Buran-Kaya III.

Thirty-six nodules and 32 cores or bifacial preforms, the latter often with considerable amounts of cortex, came from distant raw material sources and, with the exception of 4 nodules (or raw pieces) discarded as such, were reduced on-site. For what purpose were they imported and how successful was their reduction on-site? Slightly fewer than a third (29%) of all 114 imported pieces were discarded without any flaking (Figure 12-23: Bw to Nw). They belong to the tool set that was probably used during moves and at the beginning of the visits to Buran-Kaya III. Fifteen blanks or tools (14%) were initially modified or resharpened and, therefore, used on-site (Figure 12-23: Ei, TM, TM/surface, TT). Sixty-five nodules, cores, or bifacial preforms (57%) were flaked on-site (Figure 12-23 stacked and shaded bar at right), and most of them ended up in raw material units that were classified as surface shaping processes (Figure 12-23: Np/surface, Nb/surface, Nm/surface, Cb/surface, Cm/surface).

Nevertheless, some of the blanks were already modified when they entered the site. Among single pieces, 18 simple and 5 surface-shaped tools reached the site as already modified formal tools (Table 12-5). Detailed information is available only for simple tools from the transformation analysis data. Apart from 4 points and 4 retouched pieces, the typological classification of 11 sidescrapers is of special interest. In this group (Figure

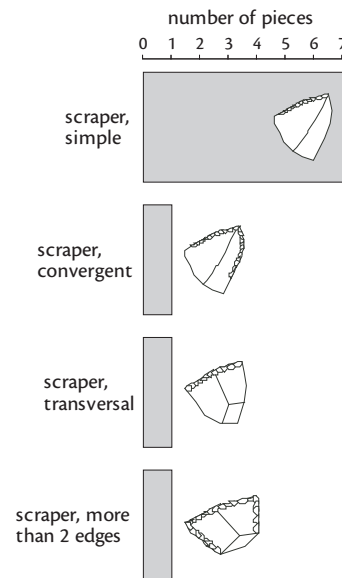

Figure 12-24—Typological classification of imported sidescrapers. Simple scrapers as the starting point of a reduction sequence reconstructed by Demidenko (Chapter 9) are more numerous, perhaps because they bear a reserve of working edges.

12-24), simple scrapers dominate (7) over convergent scrapers, transversal scrapers, and scrapers with more than 2 working edges (1 each). What conclusions can be drawn from this in respect to the factors that influenced the choice of tools taken by Neandertals while on the move? Compared with the observation of Demidenko (Chapter 9), who describes a reduction sequence of scrapers that starts with simple scrapers and ends with convergent scrapers, it can be said that, in most cases, the scrapers that were moved belong to an initial phase of this reduction sequence. Obviously, Neandertals calculated a long use-life for these scrapers in advance, because the scrapers they took on their travels have a reserve of working edges. The fact that this is not in accordance to Geneste's conclusions (1985:521) is explained by the assumption that Buran-Kaya III was reached after direct moves from previous

1 camps. Suggesting a speed of 3–4 km/h, these moves, 2 over a distance of approximately 10 to 15 km each, 3 may have taken between half a day and a day only. 4 During that time, the simple scrapers were not used 5 intensively enough to be transformed into convergent 6 scrapers.

7 For 8 surface-shaped tools, no typological information 8 is available because only tool tips were left on-site. 9 Three surface-shaped tools are only documented as 10 fragments, and 1 simple tool was exported after rejuvenation. 11 We probably have to add some more pieces of 12 unknown typological classification, however, because 13 they were imported and exported without leaving 14 any traces of their presence at the site. If hafted tools 15 were not exhausted and, therefore, resharpened or 16 retooled, then they were exported without any discard 17 when Neandertals moved to future camps.

Results of the Transformation Analysis II: On-Site Production

Because the transformation analysis treats workpieces as refits, it is possible to calculate artifacts that were produced on-site, but not found during the excavations due to N-transforms or C-transforms (Uthmeier, Chapter 11). Cores or preforms are added if a raw material unit contains only by-products of their production. Additional simple flakes (or tools) and surface-shaped tools are calculated for raw material units that include waste of modification or rejuvenation, but lack a tool.

The frequencies calculated for the overall production of blanks in Level B1 (Figure 12-25) shows a dominance of simple flakes and flakes from surface retouch. Apart from the often-stressed assumption that nearly all on-site production sequences were dedicated to surface shaping of preforms or bifacial tools, there are few other striking technological features. The absence of any target flakes from classical concepts like Levallois, discoidal, or Quina has already been mentioned. Some *couteaux à dos naturel* result from primary flaking of raw nodules, and several transverse flakes can be explained by unsuccessful knapping of flat pebbles. Because our conventional classification of Kombewa flakes looked for flakes with double ventral surfaces, thick flakes detached with hard hammer technique from bifaces or preforms, are hidden in the simple flake category.

The advantages of transformation analysis is illustrated by the additional number of 18 cores or bifacial preforms that were produced on-site, but are not found in conventional classifications because they were exported. Together with 21 unknown blanks that left the site as surface-shaped tools and 6 flakes from exported simple tools, the number of blanks that was reconstructed accounts for 45 items. If added to the

23 actual discard per transformation section, the reconstruction 24 of the minimal number of missing artifacts 25 allows a more adequate calculation of the transformation 26 index (as blanks per imported artifact: Figure 27 12-26). The calculation is based not only on blanks 28 from primary flaking and surface retouch, but also on 29 waste from modification and rejuvenation. Although 30 the index is calculated for each transformation section 31 (without differentiation of conventional debitage and 32

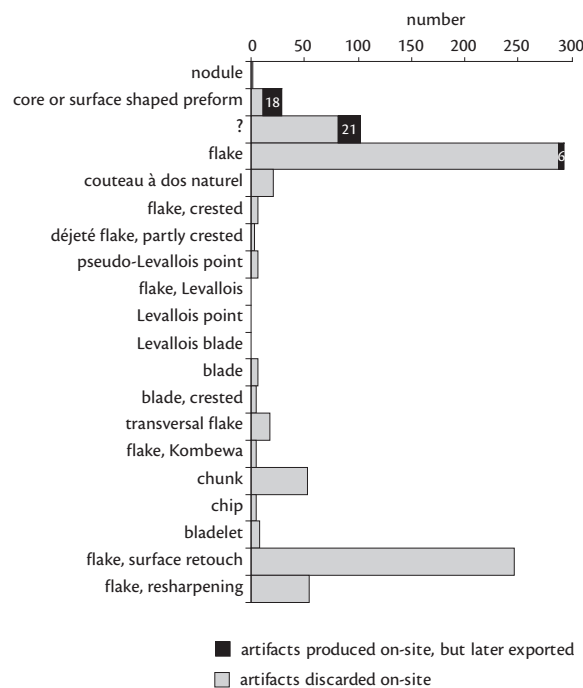

Figure 12-25—Frequencies of blanks produced on-site based on discarded items (black bars) and reconstructed items.

surface shaping), only those with blank production on-site are discussed below (Figure 12-26: Np/all to Nm/all). It is no surprise that the transformation index reaches its highest ratio in raw material units where the complete *chaîne opératoire* started with the import of a raw nodule (Figure 12-26: Nm/all). In these raw material units, on average 19.30 artifacts were detached from every nodule. With ratios between 8.50 and 6.00 artifacts per core or nodule, all others are much lower and, at the same time, quite similar. A lower index for sequences that begin with cores or bifacial preforms (Figure 12-26: Cb/all, Cm/all) is in accordance to

our expectations, because those pieces were already decorticated and/or prepared for further reduction. Comparably low ratios for nodules that ended up as prepared nodules (Figure 12-26: Np/all) or cores (Nb/all), however, need further interpretation. To us, this is best explained by the assumption that the risk of an unsuccessful reduction was recognized early, and, therefore, the production process stopped after only a few flakes were struck.

According to our classifications, a total of 189 formal tools and 59 blanks with irregular retouch were produced and discarded on-site (Table 12-5). Among

TABLE 12-5
Calculation of imported, on-site produced, and/or exported formal tools in Buran-Kaya III Level B1

	<i>Discarded on-site</i>	<i>Exported</i>
<i>Tools produced off-site, imported, and discarded</i>		
Transformation section: Tw		
Number of RMUs: 18		
simple tools, classified as:	18	
points	4	
scrapers, simple	7	
scrapers, double	1	
scrapers, transversal	1	
scrapers, more than 2 edges	1	
retouched pieces	4	
Transformation section: Tw/surface		
Number of RMUs: 4		
surface-shaped tools	5	
<i>Tools produced off-site, imported, resharpened or used and exported</i>		
Indicators: isolated resharpening flakes or tool-tips, isolated tool fragments		
Transformation section: Ei		
Number of RMUs: 11		
surface-shaped tools		8
Transformation section: TT		
Number of RMUs: 3		
surface-shaped tools		3
<i>Blanks produced off-site, imported, modified and exported or not</i>		
Indicators: isolated chips from modification, discard of tool possible		
Transformation section: TM		
number of RMUs: 4		
simple tools	1	1
surface-shaped tools	2	
<i>Tools produced on-site and discarded</i>		
Transformation section: Cm, Nm, Cm/surface, Nm/surface		
Number of workpieces: 39		
simple tools	151	
surface-shaped tools	38	
<i>Tools unquestionably produced on-site, but exported</i>		
Indicators: flakes from flaking discarded, preform or tool is missing		
Transformation section: TM, TM/surface, Cm, Nm, Cm/surface, Nm/surface		
Number of RMUs: 56		
simple tools		6
surface-shaped blanks (preforms)		5
surface-shaped tools		21
Total (all)	215	54

A Transformation index (I_t) = number of flaked artifacts ÷ number of workpieces

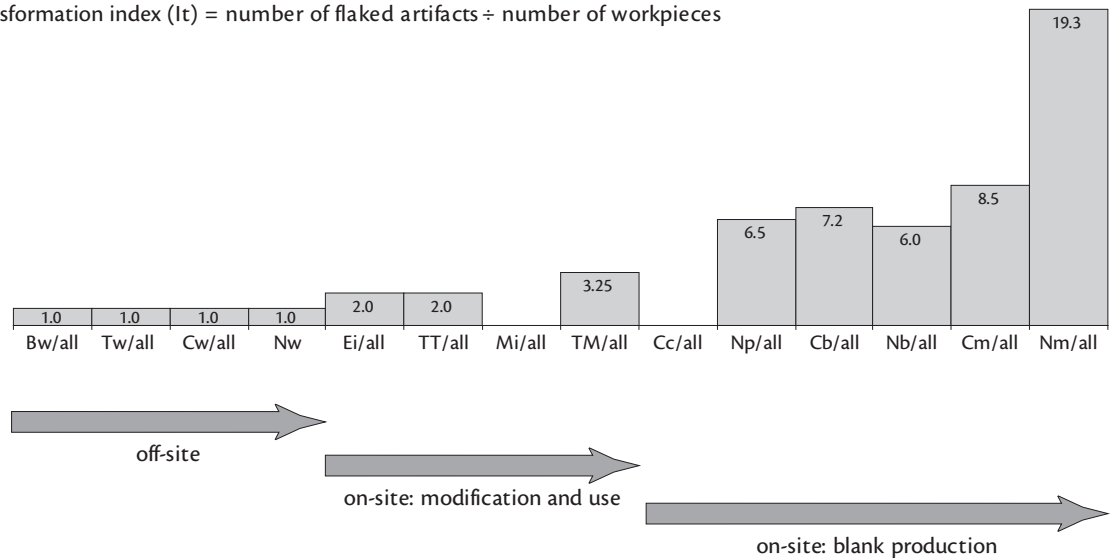

B Number of unquestionably exported artifacts

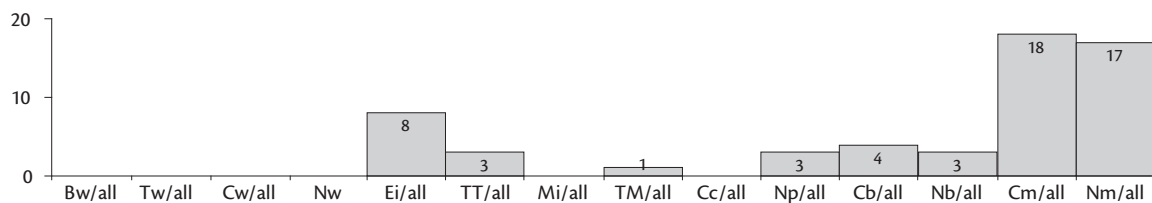

Figure 12-26—Transformation index (as artifacts per workpiece) calculated for each category of transformation sections (A) and an overview of the number of reconstructed artifacts (B).

these, 151 are simple tools dominated by points, simple sidescrapers, and convergent sidescrapers. Thirty-eight others were classified as surface-shaped tools. A

detailed description of the typology and metric data of these tools are given by Demidenko in Chapter 9 of this volume.

Results of the Transformation Analysis III: Export

In theory, incomplete raw material units might not only be caused by human transport, but also by N-transforms. Because artifacts are thought to be preserved in situ, and because the analyzed sample is considered to be more or less complete, we interpret missing artifacts here as import and export of cores, preforms or formal tools.

It has already been said that the calculations of artifacts that are supposed to have been exported are biased towards cores, bifacial preforms, and bifacial tools: they are reconstructed due to by-products that were left at the site. Only if flakes, waste of rejuvenation or fragments were left behind, a determination of the exported blank or tool is possible. However, these calculations generally tend to be too

low, because hafted tools and other artifacts might be carried to and exported from the site without being flaked. Figure 12-27 shows our minimal calculation for exported blanks. Fifteen of 54 exported artifacts were not produced on-site (Table 12-5). They represent 13 surface-shaped tools of unknown typological classification that were imported, and, after resharpening or intensive use, exported, as well as 2 simple tools with similar histories. Because only tool tips, rejuvenation flakes, or small fragments were discarded, the actual blank cannot be reconstructed. The same problem occurs for 21 artifacts that come from raw material units with on-site production and modification of surface-shaped blanks. Comparable to the previous category, they are represented only by

1 surface flakes of their production and waste of their
 2 rejuvenation. The only information is that they were
 3 surface-shaped tools, yet of unknown typological
 4 classification and blank type. Among 18 cores and
 5 preforms, 5 were reconstructed as surface-shaped pre-
 6 forms because flakes from surface retouch occurred
 7 in the corresponding raw material units. The remain-
 8 ing 13 items had to be reconstructed as cores, because
 9 no flakes from surface retouch were found among
 10 the by-products.

11 The impression that mainly products of surface
 12 shaping were exported (within a cycle of use discard,
 13 and retooling and rehafting described by Richter in
 14 Chapter 13) is not entirely correct, because simple
 15 flakes might also have been taken to future camps
 16 without being recognized. It is still interesting,
 17 however, on the basis of minimal calculations, that
 18 from 34 nodules and 30 cores or bifacial preforms
 19 that entered the concentration (Figure 12-28), 21
 20 surface-shaped tools, 5 surface-shaped preforms, and
 21 13 cores were produced that left the site. Because sur-
 22 face-shaped tools were made from nodules and flakes,
 23 another 38 surface-shaped tools that were discarded
 24 also came from these. Altogether, these account for a
 25 minimum of 73 pieces related to surface shaping that
 26 were produced on-site.

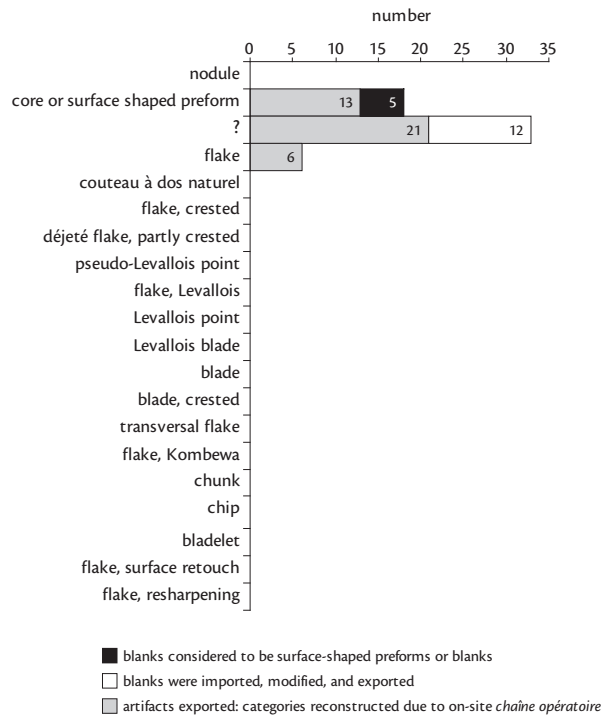

Figure 12-27—Frequencies of exported blanks based on discarded tool tips or waste from rejuvenation (black bars) and reconstructed items.

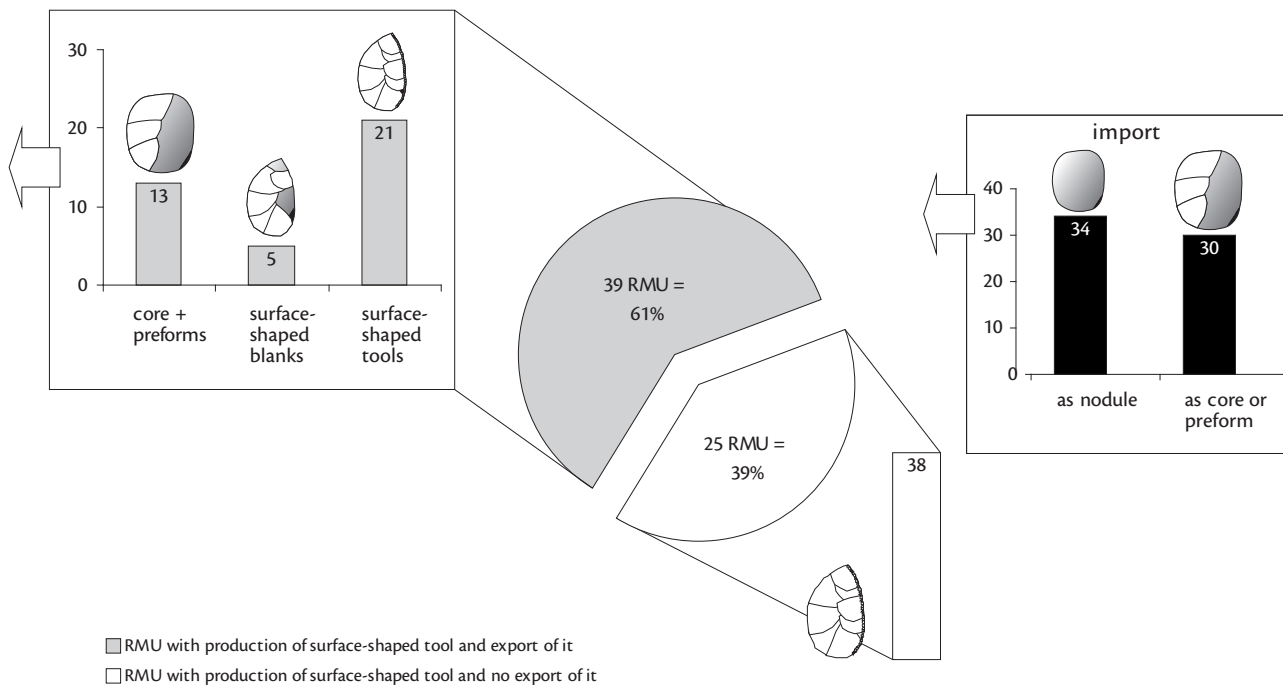

Figure 12-28—Biography of raw material units that entered the site as nodules or preforms in respect to their output of surface-shaped (bifacial) tools, preforms, or cores.

Conclusion: Distant Raw Material, Saiga Hunting, and Planning Depth

The diagrams in Figures 12-29 to 12-31 summarize the results of the transformation analysis of Level B1. Artifacts that were brought to the site of Buran-Kaya III (Figure 12-29) are dominated by raw material nodules (33%). An additional 25% were imported as cores or as bifacial preforms. This indicates primary flaking of raw material directly at the outcrops or at nearby campsites, approximately 10 to 15 km away from Buran-Kaya III. From previous campsites, surface-shaped tools, which account for 18% of all imported artifacts, were carried to Buran-Kaya III. Seventeen percent of all artifacts taken on the move were simple tools that typologically often belong to the category of simple scrapers. Only 7% were unmodified blanks.

Most artifacts that were produced and discarded on-site (Figure 12-30) were simple flakes of different shapes (41%), followed by flakes derived from surface retouch (30%) and waste of rejuvenation (13%). Some cores (1%) and surface-shaped preforms (5%) were also left behind, perhaps due to unsuccessful preparation.

Export (Figure 12-31) is characterized by high frequencies of surface-shaped tools (57%). Many cores with cortex (23%) represent raw nodules that were not consumed on-site after primary flaking.

There is no doubt that late Neandertals planned their visits to Buran-Kaya III Level B1 in advance (Figure 12-32: 4-7). Because local raw material was not available, a minimum of 4.2 kg of selected flint plaquettes, flat round flint pebbles, and preforms were carried over a distance of 10 to 15 km to the site (Figure 12-1). A distance of 10-15 km is well inside the radius of

20 km suggested for "site territory" by H. Floss (1994: 323). Although it cannot be excluded that the transport of raw material is the result of moves from previous camps to the small rockshelter at the Burulcha that belong to "residential mobility" (Binford 1980), e.g., complete (family-sized?) groups visited the site, it seems more probable that "task groups" repeatedly visited Buran-Kaya III during the time of Level B1. If it is true that mainly adult Neandertals were hunting large game, as P. Pettitt (1998) suggests, then small "task groups" of adult Neandertals came from a base camp most probably situated near the raw material sources at Tsvetochnoye or Russakovka. After some days, dedicated to special activities, they returned. The hypothesis that Neandertals of Level B1 used a "logistical" strategy for resource acquisition (Binford 1980), with "occasional camps" (Higgs and Vita-Finzi 1972: 30) near places of rich food resources, best explains why considerable amounts of raw material were transported in one move to a site where only one species was hunted. Such communities of hunter-gatherers, who live as "logistical collectors" (Binford 1980), are often expected from the Upper Paleolithic onwards, but not for the Middle Paleolithic (Floss 1994:323).

The analysis of the faunal remains showed that *Saiga tatarica* was the most important game hunted at Buran-Kaya III Level B1 (Patou-Mathis, Chapter 8). This species is known to live in large herds that are highly mobile, not only during seasonal migrations, but also during the day. Daily distances of over 100 km have been reported (Reicholf 1996:250). At the

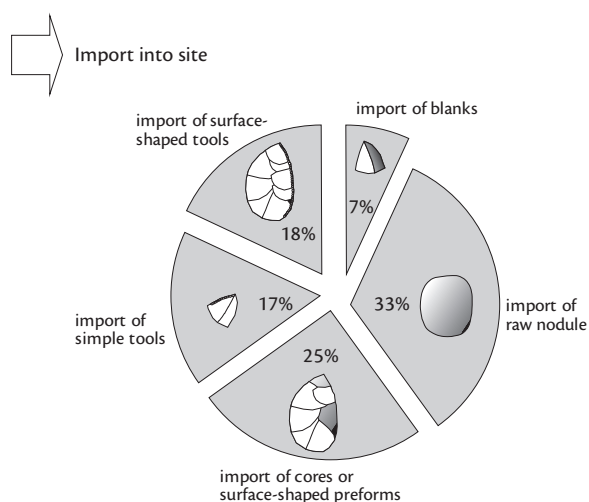

Figure 12-29—Comprehensive illustration of imported artifacts.

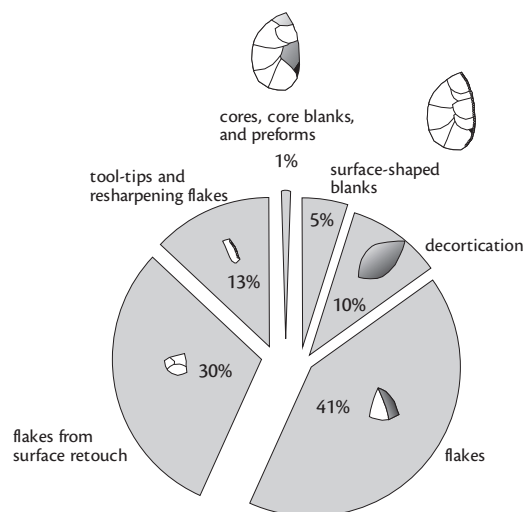

Figure 12-30—Comprehensive illustration of artifacts produced and discarded on-site.

1 same time, the weight of adult individuals ranges
 2 between 32 kg for females and 43 kg for males. The
 3 low individual body weight and the high mobility of
 4 the herds suggest that the hunting of *Saiga tatarica*
 5 migrating between the Crimean Mountains and the
 6 northern steppe was promising, but connected with
 7 high costs of activities other than hunting. The recon-
 8 structed scenario of a specialized hunting camp for
 9 a highly mobile species, far away from raw material
 10 sources, leads to the hypothesis that it was necessary to
 11 minimize the working hours dedicated to the procure-
 12 ment of raw material and the production of artifacts
 13 needed for killing and butchering. Thus, the stay at
 14 Buran-Kaya III required detailed planning.

15 The observation that some of the nodules were
 16 already decorticated can be interpreted as testing of
 17 the nodules to minimize the danger of fissures and
 18 cracks that might lead to unsuccessful core reduction.
 19 The transported raw material was expensive. Therefore,
 20 many by-products of the production of mainly sur-
 21 face-shaped preforms or tools were used as blanks for
 22 simple tools (Figure 12-32: 5), and many formal tools
 23 underwent long reduction sequences of resharpening
 24 and rejuvenation, leading to many convergent simple
 25 tools (Demidenko, Chapter 9) and exhausted bifacial
 26 tools (Richter, Chapter 13). In a number of cases, sur-
 27 face-shaped preforms and broken bifacial tools were
 28 used as cores for Kombewa-like flakes before being
 29 discarded (Figure 12-32: 7). Hafting and, therefore,
 30 re-tooling, was important, as well (Figure 12-32: 2).
 31 The analysis of the operational steps of surface-shaped
 32 tools (Richter, Chapter 13) showed that bifacial tools
 33 were resharpened while hafted (Figure 12-32: 3). It is

most likely that some of the simple formal tools, such
 as simple scrapers, convergent scrapers, or points,
 were hafted as well. Re-tooling and re-hafting most
 probably happened on-site. The intensive export of
 surface-shaped preforms and surface-shaped tools,
 however, suggests that this process, as well as other
 flaking sequences, also happened at hunting stands
 (Figure 12-32: 5). In addition, it is also possible that
 some of the tools that were imported, resharpened,
 and later exported are evidence for movement back
 and forth from Buran-Kaya III and contemporaneous
 ephemeral camps (Figure 12-32: 4, 5, 8).

The artifacts of Buran-Kaya III Level B1 indicate
 that Crimean Neandertals indeed were prepared for
 anticipated periods. Because they were bringing all
 raw material to the site and chose methods of stone
 tool production that avoided the need for new raw
 material supplies, they minimized the costs of blank
 and tool production. The fact that raw material
 procurement was not embedded in other activities,
 with an intensive going to and coming from local or
 regional raw material outcrops, but a result of planned
 macro-moves from one camp to another, carrying
 both curated tools and calculated amounts of raw
 nodules, indicates a high degree of planning depth
 (Roebroeks et al. 1988).

How long were the visits at Buran-Kaya III Level
 B1? Table 12-6 gives the minimal duration for the pure
 labor connected with the production and use of stone
 tools found during the 1996 excavation, calculated
 in reference to data from archeological experiments
 (Schütz et al. 1990; Kind 1987; Veil 1990). In total,
 247.7 hours of pure labor were spent for blank pro-
 duction, retouch, and rejuvenation (51.05 hours), but
 mainly for the use of formal tools (196.65 hours). If
 a working day is calculated as 10 hours with daylight,
 this accounts for 24.5 working days. However, the
 time needed for the gathering of wood for fires, water,
 and other activities necessary to establish a camp is not
 included. The hunting of a highly mobile species such
 as *Saiga tatarica* should be more successful if several
 individuals cooperate. If it is true that Neandertals
 lived in family sized groups (Gamble 1999:266), then
 a group numbering between two to four working
 individuals seems most probable. Therefore, it can be
 assumed that the total amount of pure labor ranges
 between 12 days (two individuals), 8 days (three
 individuals) and 6 days (four individuals). Because
 fireplaces were used, it is unlikely that a visit lasted
 only several hours. Calculating days, it was probably
 some three to six visits of several days each, dedi-
 cated to the hunting of *Saiga tatarica* in the small valley
 of the Burulcha River, that led to the assemblage of
 Buran-Kaya III Level B1.

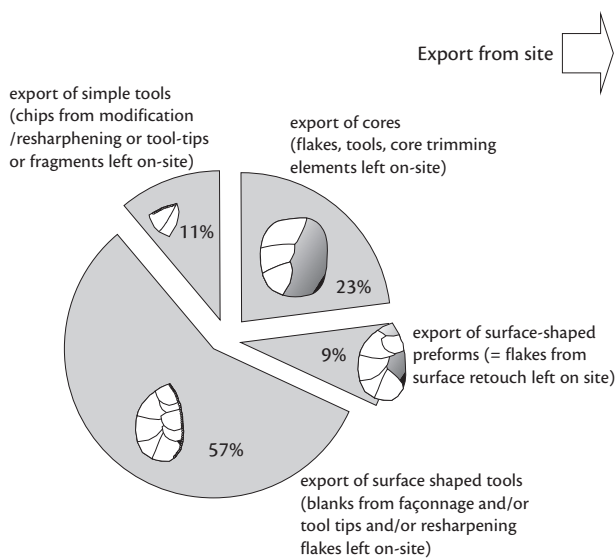

Figure 12-31—Comprehensive illustration of exported artifacts.

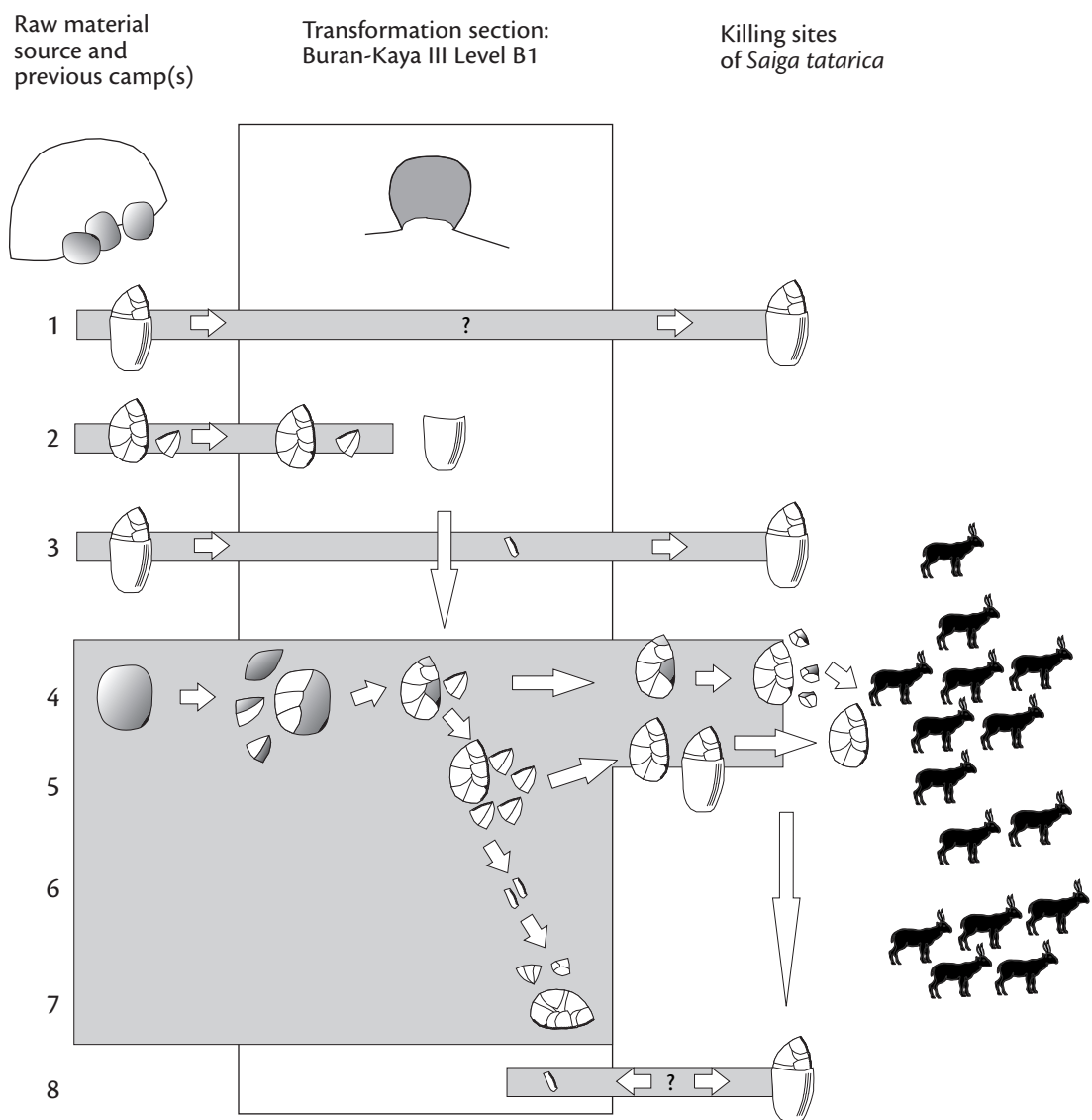

Figure 12-32—Activities in terms of import, on-site flaking and discard, and export. It is assumed that costs for raw material procurement, artifact production, and camp supplies are high during the hunting of extremely mobile *Saiga tatarica* herds. 1—hafted tools carried but not used on the site; 2—tools imported and discarded (after re-tooling?); 3—tools imported and exported after resharpening; 4 to 7—raw material units imported and reduced on-site into cores and preforms (4), surface shaped tools (5), surface shaped tools that are resharpened (6) or exhausted bifacial pieces used as cores (7); 8—tools carried from hunting stand to Buran-Kaya III Level B1.

TABLE 12-6

Calculation of pure time of labor for the production and use of all formal tools found and reconstructed. (Calculation based on experiments in Kind 1987; Schütz et al. 1990; Veil 1990.)

<i>Activity</i>	<i>Time of production or use estimated for each piece (in minutes)</i>	<i>Comment</i>	<i>Number of workpieces</i>	<i>Comment</i>	<i>Estimated time in minutes</i>	<i>Estimated time in hours</i>	<i>Estimated time in days, 10 hours of labor each</i>
<i>Production of artifacts</i>							
Reduction/preparation of core	30		65	overall imported cores and nodules	1,950	32.5	3.2
Modification of a surface blank	9		73	40 surface shaped tools discarded on-site + 33 exported tools + 2 pieces imported, but modified on-site	657	10.95	1
Modification of a simple blank	3		152	152 simple tools discarded on-site + 2 tools imported and modified on-site	456	7.6	0.7
<i>Use of artifacts</i>							
Use of a simple tool, 1 working edge	18	15 min. use of modified tool + 3 min. use of simple blank	81	57 simple scrapers + 8 déjeté scrapers + 7 transversal scrapers + 9 other types	1,458	24.3	2.4
Use of a reduced simple tool, 2 working edges	33	30 min. use of modified piece + 3 min. use of simple blank	62	47 points + 3 double scrapers + 12 convergent scrapers	2,046	34.1	3.4
Use of reduced simple tool, 3 working edges	48	45 min. use of modified piece + 3 min. use of simple blank	4	scrapers with more than 2 edges	192	3.2	0.3
Use of surface shaped tool	180	4 times longer than simple tools, estimated after Richter (Chapter 13)	45	40 surface shaped tools use and discarded + 5 surface shaped tools imported and discarded	8,100	135	13.5
Total					14,859	247.65	24.5

